



PLAN ID TSTDEP24002783

PIN CODE 56231D

[Open Project](#)

DATE MODIFIED 25-Apr-2024

PROJECT NAME

CLIENT NAME

PROJECT ID

SITE ADDRESS

OVERVIEW

item list

Installation

Design Layout
Structure design layout
Structure joist layout
Structure support layout
Structure Support Legende
Cutting list surface products
Cutting list joists
Cutting list perimeter
Product Information Package
Product Information

Merchant Planner Install

Call 07564582442
Email sales@decking-e-commerce.co.uk
Web www.decking-e-commerce.co.uk

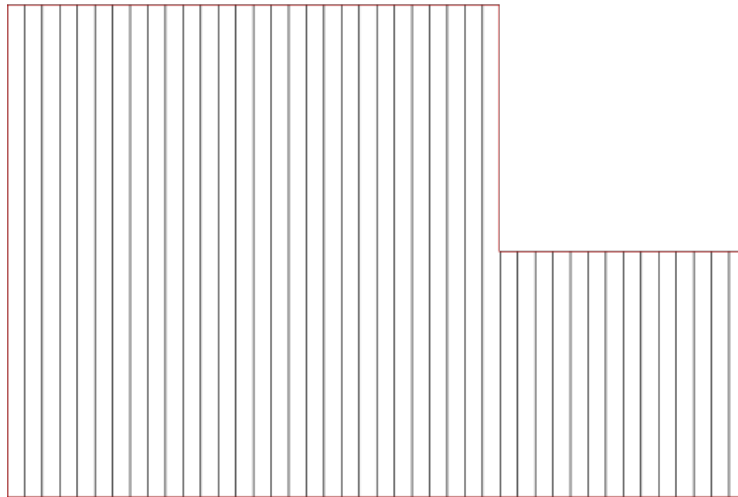

DESIGN SPECIFICATIONS

Deck height 40 cm
Substrate Grass and soil
Frame Type Joist / Drop Beam / Rim Joist
Anchored installation Yes

SELECTIONS

Surface UltraShield Antique Composite Decking Boards
Joist carcassing 47 x 150 mm
Beam carcassing 47 x 100 mm
Joist centers 40 cm
Joist span 2,300 mm
Beam span 1,600 mm
Beam carcassing 47 x 150 mm

DECK AREAS

Deck Number	Area	Perimeter	Joist centers
Area A	20 m ²	20.00 m	40 cm

ITEM LIST



SURFACE

		Qty.		\$ / uom	1,621.20 £
	DECKING UltraShield Antique Composite Decking Boards 23 x 138 mm, Lengths: 4 800 mm, Code:: DECK.US.GR-4800	35 pcs	168 m	9.65 £ / m	1,621.20 £

STRUCTURE

		Qty.		\$ / uom	462.29 £
	JOIST carcassing 47 x 150 mm 150 x 47 mm, Lengths: 3 000 mm, Code:: TIM.FRAM.150.47-3000	8 pcs	24 m	4.52 £ / m	108.48 £
	JOIST carcassing 47 x 150 mm 150 x 47 mm, Lengths: 4 200 mm, Code:: TIM.FRAM.150.47-4200	12 pcs	50.40 m	4.52 £ / m	227.81 £
	BEARER carcassing 47 x 100 mm 100 x 47 mm, Lengths: 3 000 mm, Code:: TIM.FRAM.100.47-3000	1 pcs	3 m	3.00 £ / m	9.00 £
	BEARER carcassing 47 x 100 mm 100 x 47 mm, Lengths: 4 200 mm, Code:: TIM.FRAM.100.47.4200	3 pcs	12.60 m	3.00 £ / m	37.80 £
	BRACKET steel connector joist joiner Code:: STEEL.FRAM.JJ	24 pcs	0 m	1.00 £ / m	24.00 £
	BRACKET Universal joist hanger for 100 mm and 150 mm joists Code:: JHJ	46 pcs		1.20 £ / pcs	55.20 £

SURFACE FIXINGS

		Qty.		\$ / uom	176.20 £
	CLIPS Standard clips Code:: wpcclip2	381 pcs	2 Box	78.80 £ / Box	157.60 £

ITEM LIST



SURFACE FIXINGS

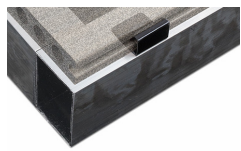

START- & ENDCLIPS

Starter clips

Code:: wpclip5

Qty.	\$ / uom	176.20 £
11 pcs	2 Box 9.30 £ / Box	18.60 £

VENTILATION



WEEDMATS

Ground cover weed control

Code:: fabb

Qty.	\$ / uom	16.64 £
2 pcs	8.32 £ / pcs	16.64 £

SUPPORTS



POSTS

half bag of post mix

Code:: PM0.5

Qty.	\$ / uom	213.12 £
15 pcs	8 Box 6.00 £ / Box	48.00 £



POSTS

1.2 x 75 x 75 (2 ex 2.4) post

75 x 75 x 2.400 mm, Code:: TIM.75.75

15 pcs	8 Box 20.64 £ / Box	165.12 £
--------	---------------------	----------

SERVICES AND DOCUMENTS



INSTALLATION GUIDES

All project plans, cutting lists and instructions to use the above goods to create your chosen deck.

Code:: PLAN

Qty.	\$ / uom	0.00 £
1 pcs	0.00 £ / pcs	0.00 £

Subtotal **2,489.45 £**

20% GST **497.89 £**

Grand total (incl. GST) **2,987.34 £**

DESIGN LAYOUT



This information is for calculation purpose only. Before starting installation, check all dimensions. Refer to installation instructions, site conditions and governing regulations.

UltraShield Antique Composite Decking Boards (DECK.US.GR-4800)

Area: 20 m², Perimeter: 20.00 m

Joist centers: 40 cm

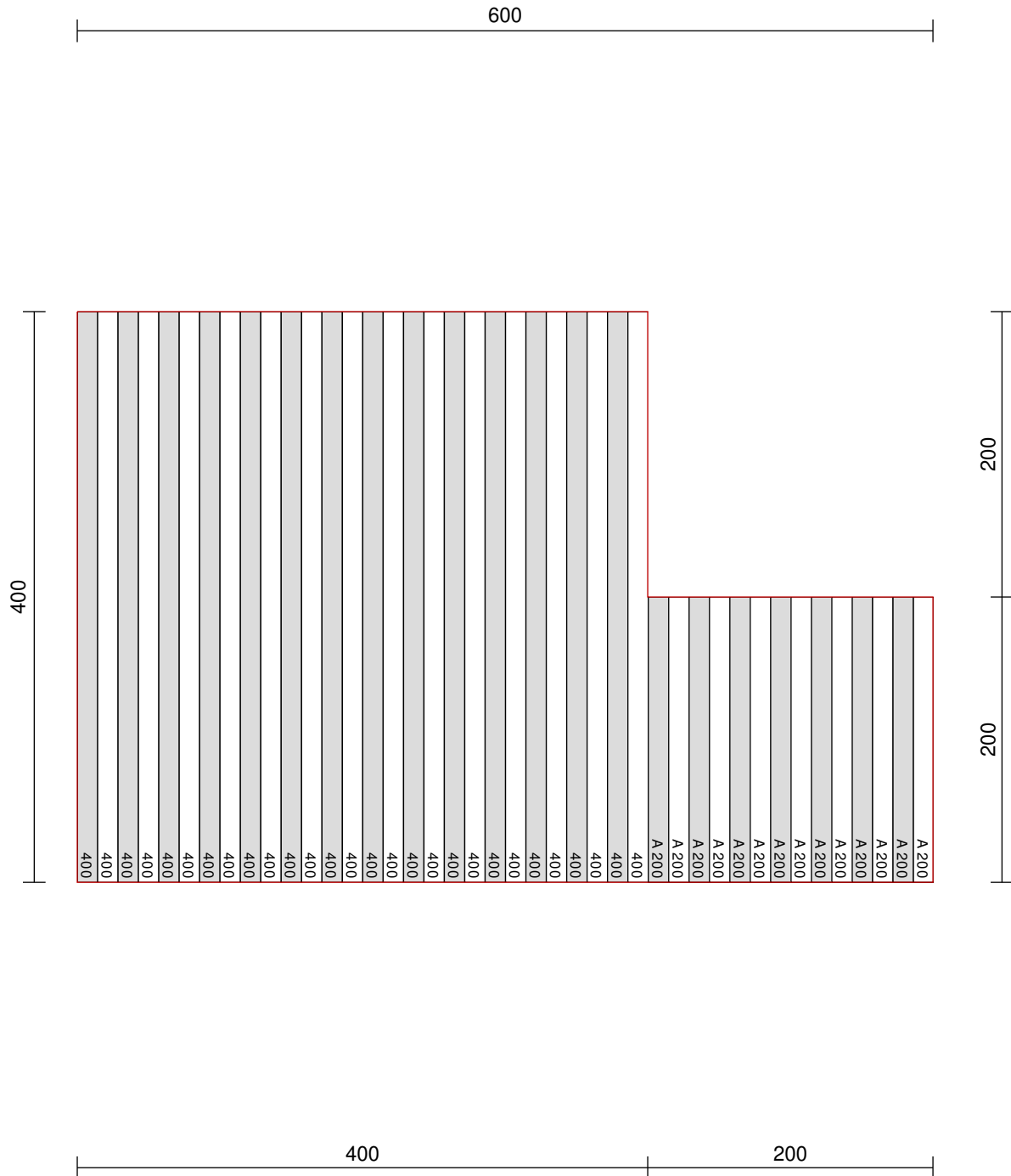

STRUCTURE DESIGN LAYOUT



This information is for calculation purpose only. Before starting installation, check all dimensions. Refer to installation instructions, site conditions and governing regulations.

- Joist: carcassing 47 x 150 mm (TIM.FRAM.150.47)
Joist centers: 40 cm, span: max. 2,300 mm, cantilever: max.
- Beam: carcassing 47 x 100 mm (TIM.FRAM.100.47)
span: max. 1,600 mm, cantilever: max. 100 mm
Anchored installation: Yes

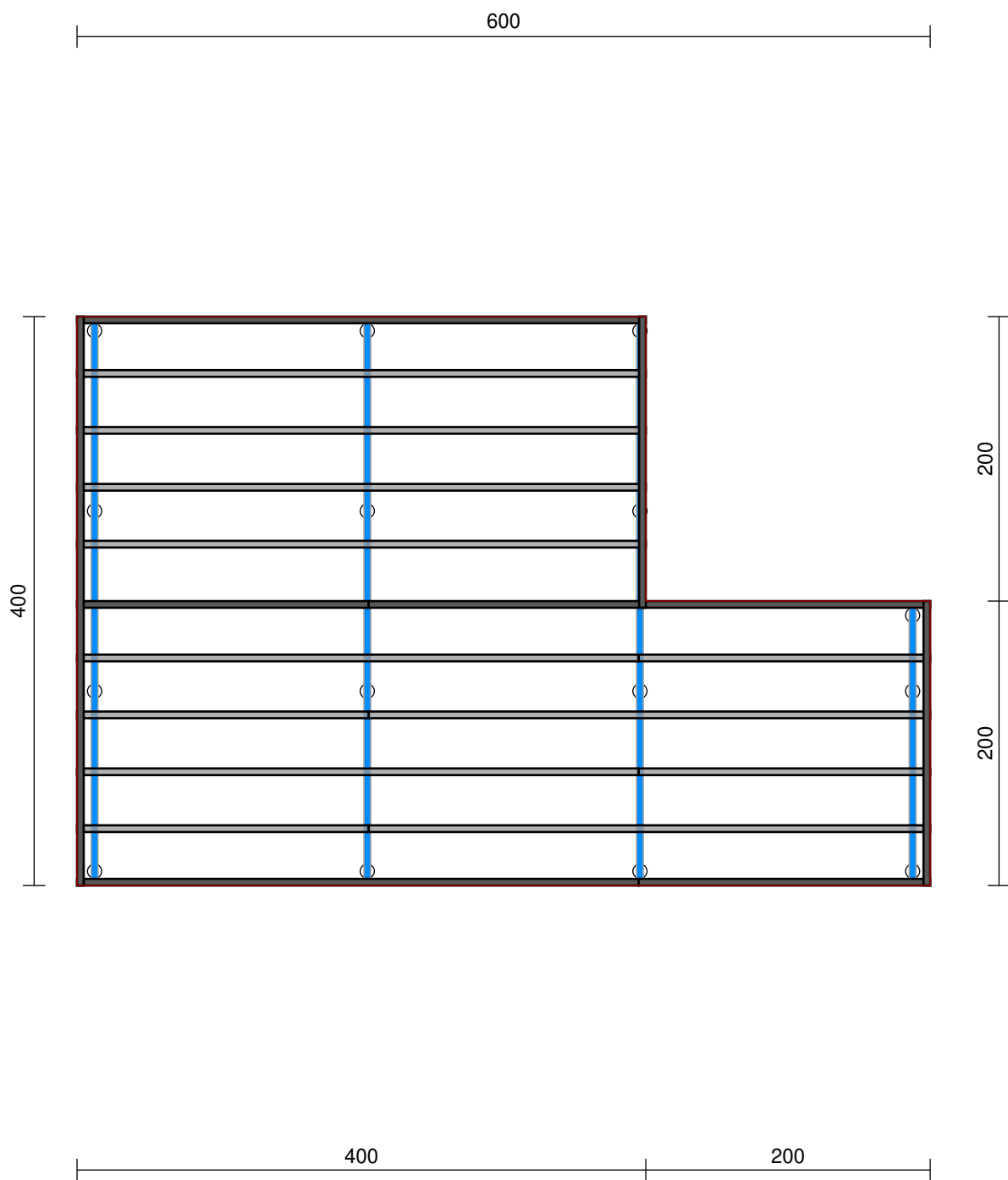

STRUCTURE JOIST LAYOUT



This information is for calculation purpose only. Before starting installation, check all dimensions. Refer to installation instructions, site conditions and governing regulations.

Joist: carcassing 47 x 150 mm (TIM.FRAM.150.47)
Joist centers: 40 cm, span: max. 2,300 mm, cantilever: max.
Anchored installation: Yes

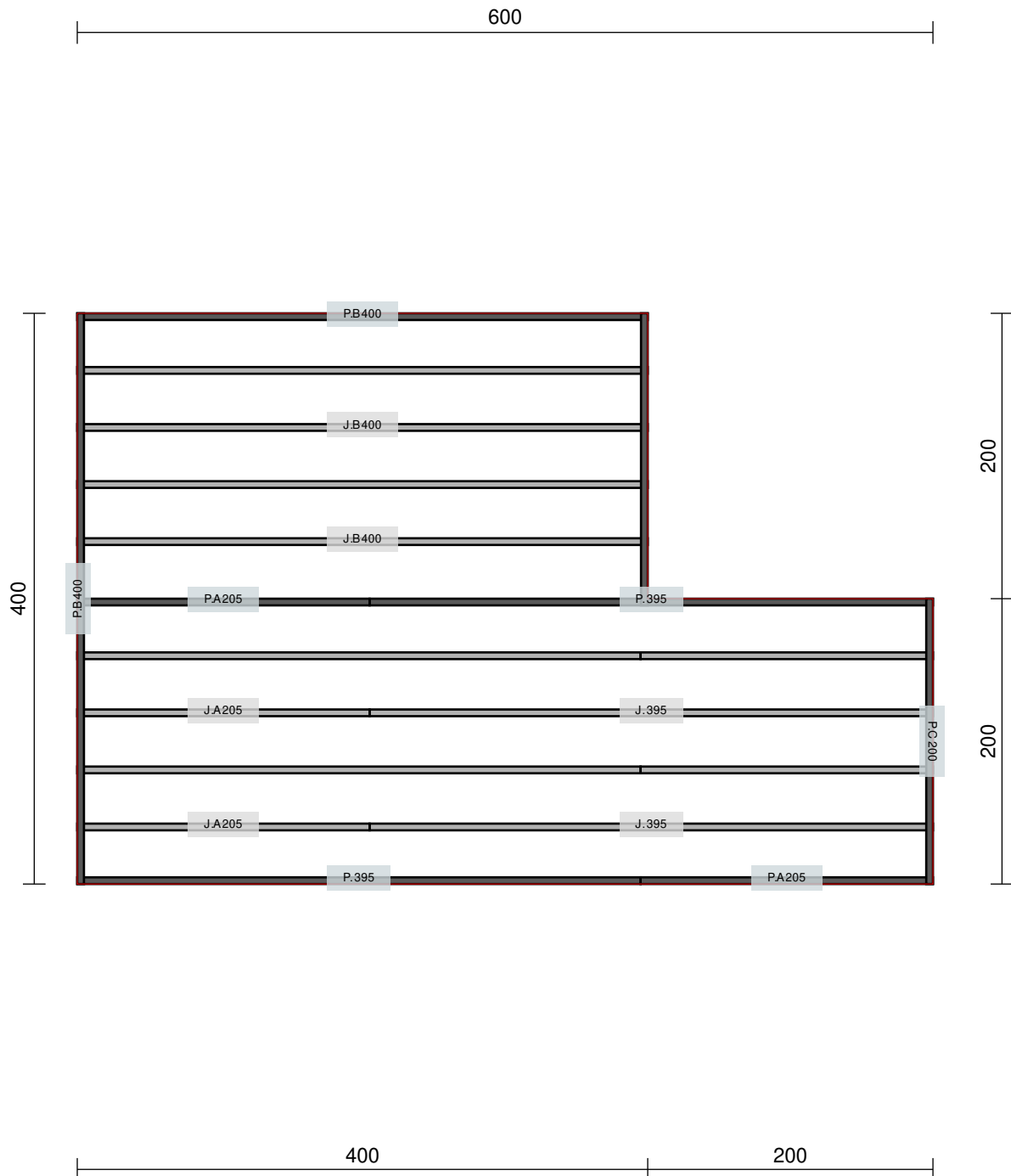

STRUCTURE SUPPORT LAYOUT



This information is for calculation purpose only. Before starting installation, check all dimensions. Refer to installation instructions, site conditions and governing regulations.

Beam: carcassing 47 x 100 mm (TIM.FRAM.100.47)
span: max. 1,600 mm, cantilever: max. 100 mm
Anchored installation: Yes

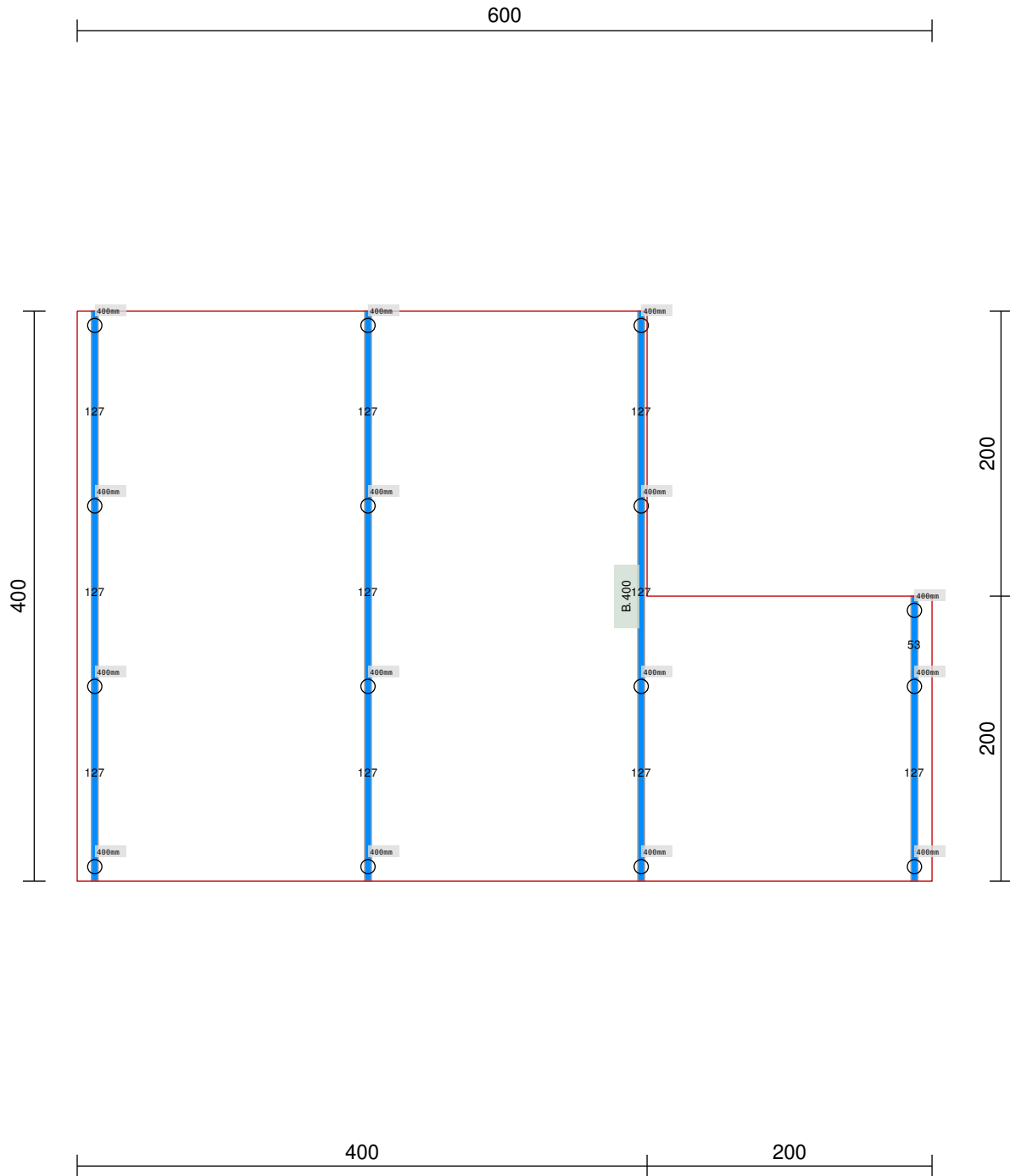

CUTTING LIST SURFACE PRODUCTS



This information is for calculation purpose only. Before starting installation, check all dimensions. Refer to installation instructions, site conditions and governing regulations.

Area A

Pieces	Volumen	Cut	Pieces	Volumen	Cut
28 pcs.	/ 480 cm	400	7 pcs.	A / 480 cm	200 200
		<input type="text"/>			<input type="text"/>

CUTTING LIST JOISTS



This information is for calculation purpose only. Before starting installation, check all dimensions. Refer to installation instructions, site conditions and governing regulations.

Area A

Pieces	Volumen	Cut
4 pcs.	J. / 420 cm	395
4 pcs.	J.B / 420 cm	400

Pieces	Volumen	Cut
4 pcs.	J.A / 300 cm	205

CUTTING LIST BEARER



This information is for calculation purpose only. Before starting installation, check all dimensions. Refer to installation instructions, site conditions and governing regulations.

Area A

Pieces	Volumen	Cut
3 pcs.	B. / 420 cm	400 <input type="text"/>

Pieces	Volumen	Cut
1 pcs.	B.A / 300 cm	200 <input type="text"/>

CUTTING LIST PERIMETER



This information is for calculation purpose only. Before starting installation, check all dimensions. Refer to installation instructions, site conditions and governing regulations.

Area A

Pieces	Volumen	Cut	Pieces	Volumen	Cut
2 pcs.	P. / 420 cm	395 	3 pcs.	P.A / 300 cm	205
2 pcs.	P.B / 420 cm	400 	1 pcs.	P.C / 300 cm	200

Construction with Grass Soil using drop post:

1. Mark out the hole positions from your plan. Dig the holes 15cm in diameter and 30cm deep. (no postmix at this point)
2. Cut the posts to the suitable height and put in the holes
3. Cut the bearers and fix to the posts.
4. Jam the bearers and posts into position remember the run off for the water on the deck. You can raise and drop using stones or slate under the posts as packers
5. When you are fully satisfied with the position read instructions on the postmix bag and fill (half a bag)
6. It is important that the postmix sets solid as per the instructions before you start building the frame on top as per the plans.

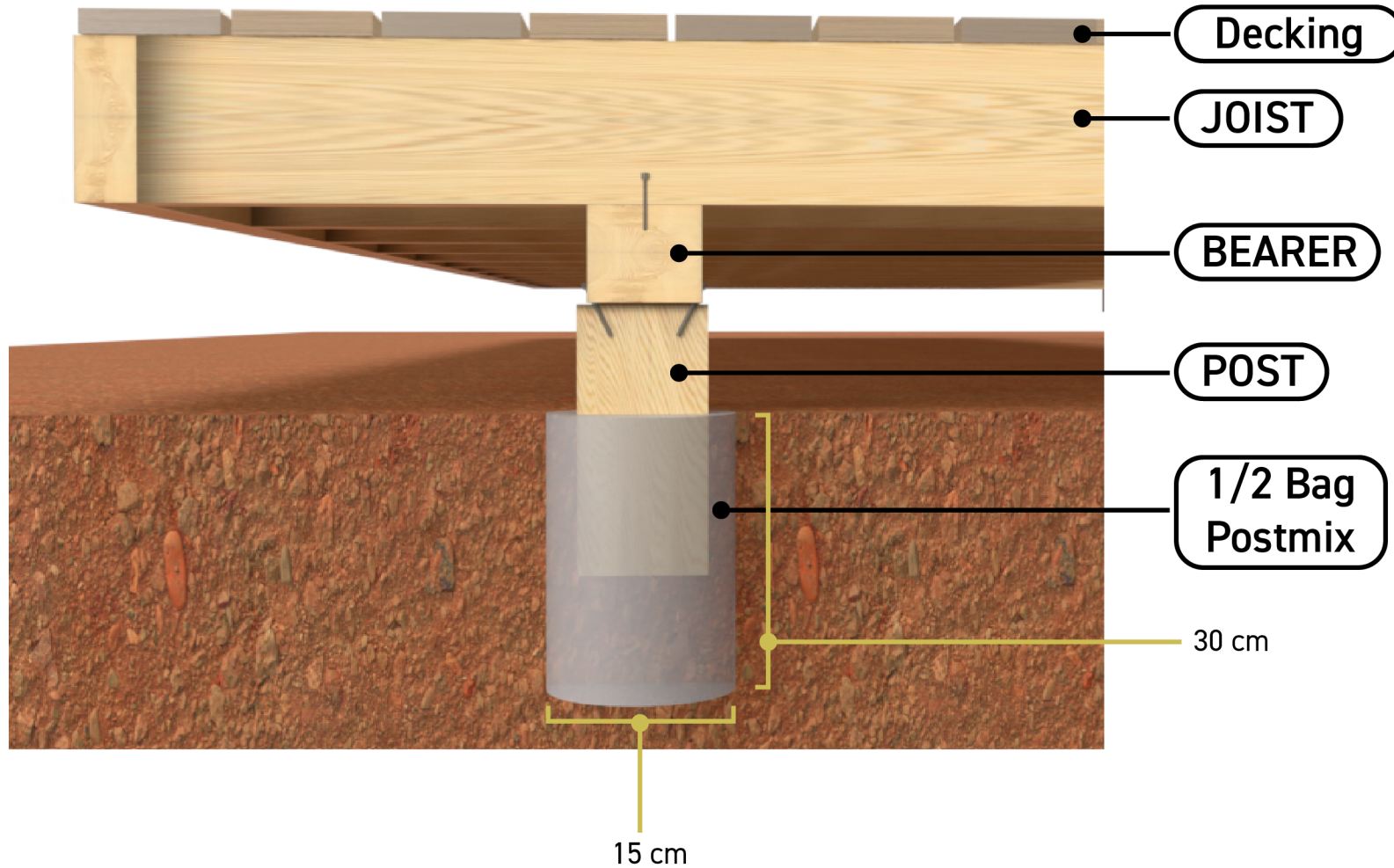



Decking Installation Guide

O21GE18UK



NewTechWood

CONTENTS

Important Note	3 - 6
Joist Installation for Framing	7
Expansion and Contraction Values	8
Locking the Decking Board	9 - 13
Breaker Board Installation	14 - 15
Stair Treads Installation	16
Bullnose Installation	17 - 18
Decking Installation	19 - 24

IMPORTANT NOTE:

Read All Sections Before You Start

For the most up to date information, please visit our website @ www.newtechwood.uk

Prior to installing any composite decking, it is recommended that you check with local building codes for any special requirements or restrictions. The diagrams and instructions outlined in this guide are for illustration purposes only and are not meant or implied to replace a licensed professional. Any construction or use of NewTechWood must be in accordance with all local zoning and/or building codes. The consumer assumes all risks and liability associated with the construction and use of this product.

Safety

When dealing with any type of construction project, it is necessary to wear appropriate safety equipment to avoid any risk of injuries. NewTechWood recommends but is not limited to the following safety equipment when handling, cutting, and installing NewTechWood: gloves, a respiratory protection, long sleeves, pants, and safety glasses.

Tools

Standard woodworking tools may be used. It is recommended that all blades have a carbide tip. Standard stainless steel or acceptable coated deck screws and nails are recommended.

Environment

A clean, smooth, flat, and strong surface is needed to install NewTechWood's products correctly. Please check with local building codes before ever installing any type of decking. If installation does not occur immediately, NewTechWood's products need to be put on a flat surface at all times. It should NEVER be put on a surface that is NOT flat.

If there is masonry work being processed, please cover the deck boards entirely to avoid the deck boards being worn or damaged by the dust and waste material generated from the masonry work.

Planning

Plan a layout for your decking before starting it to ensure the best possible looking decking for your project. Building codes and zoning ordinances generally apply to permanent structures, meaning anything that is anchored to the ground or attached to the house. So nearly every kind of decking requires permits and inspections from a local building department. We recommend drawing out a site plan of your proposed project that you intend to do to minimize errors and make your perfect decking.

Pressure wash on a scrap piece of material before using a pressure washer on the profiles to make sure that your settings will not damage the Ultrashield coating.

Construction

NewTechWood UltraShield is NOT intended for use as columns, support posts, beams, joist stringers, support against a force, or other primary load-bearing members. NewTechWood must be supported by a code-compliant substructure. While NewTechWood products are great for retrofits, NewTechWood's products CANNOT be installed on existing decking boards.

Static

Static can also be more prevalent in areas that are of higher altitude because the humidity is lower. For these areas, be careful of using conducive objects such as metal railing and chairs as static shocks might occur more often. A potential way to lower the amount of static shocks occurring is to apply an anti-static product to your deck or use anti-static mats before doorways. NewTechWood's products have been tested against EN 1815 - Assessment of Static Electrical Propensity and have received values under the maximum standard of 2kV.

Ventilation

NewTechWood products CANNOT be directly installed onto a flat surface. It must be installed onto a substructure that is made into a frame, so there is adequate and unobstructed air flow under the decking to prevent excessive water absorption. If there is excessive water absorption to any area that does not have the protection of the cap layer, there could be some swelling that occurs. A minimum of 100mm (3 15/16") of continuous net free area under the decking surface is required for adequate ventilation on all decking, so air can circulate between adjacent members to promote drainage and drying. In the case that installation is below 100mm (3 15/16"), it is recommended to look up the maximum rainfall of the area to determine what height would need to be built to ensure no flooding of the deck occurs. We recommend a slope of 1-2% must be used on the frame towards the direction of the drainage to ensure that there is no free standing water.

Heat and Fire

Excessive heat on the surface of NewTechWood products from external sources such as but not limited to fire or reflection of sunlight from energy efficient window products. Low-emissivity (Low-E) glass can potentially harm NewTechWood products. Low-E glass is designed to prevent passive heat gain within a structure and can cause unusual heat build-up on exterior surfaces. This extreme elevation of surface temperatures, which exceeds that of normal exposure, can possibly cause NewTechWood products to melt, sag, warp, discolor, increase expansion/contraction, and accelerate weathering.

Current or potential NewTechWood customers that have concerns about possible damage by Low-E glass should contact the manufacturer of the product which contains Low-E glass for a solution to reduce or eliminate the effects of reflected sunlight.

Fasteners

When fastening NewTechWood's products, all screws that are face fastened should always be driven in at a 90 degree angle to the decking surface. Toe nailing/screwing should never be done to the products. An extra joist should be added if a 90 degree angle cannot be driven into the board, as shown in [***Diagram 1***](#).

All fasteners should be on their own independent joists, when two boards ends meet each other there must be a sister joist with a minimum of 5mm (3/16") between the sister joists for water to go down between the joists. Excessive build up of water over long periods of time at the ends could result in swelling. The end of each board must sit on its own joist as shown in [***Diagram 2***](#).

Use white chalk, straight boards, or string lines as templates for straight lines. NEVER USE COLORED CHALK. Colored chalk will permanently stain NewTechWood's products and are highly not recommended. All nails/screws that are face fixed should always be stainless steel. When face fixing, always go in at least from the ends and width of the board by 38.1 mm (1 1/2") as shown in [***Diagram 3***](#).

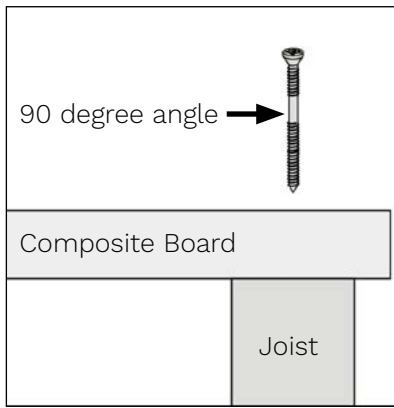

DIAGRAM 1

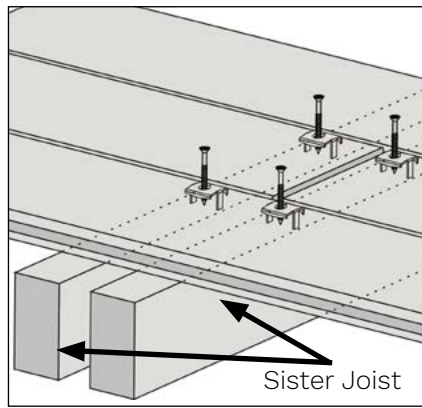

DIAGRAM 2

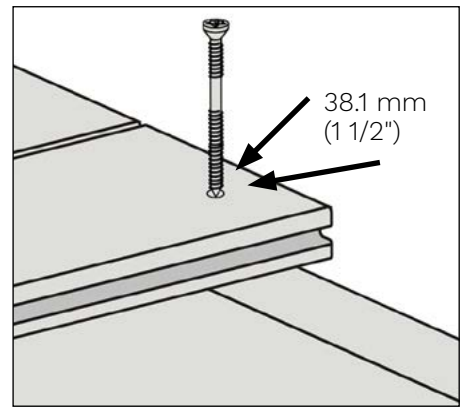

DIAGRAM 3

Fasteners Continued

Always use screws designated for use with composite decking material. Always test the screws on a scrap piece of board to ensure the screws do not cause the surface of the decking to mushroom or bulge around the head of the screw. If it does cause this issue, change to a different brand of screw.

When choosing which screws/nails to use, always check first with your local home centers and hardware stores to see if they have screws that are engineered specifically for composite wood. These screws/nails will always work and give NewTechWood's products the best looking outcome, using other screws/nails that are not recommended for composite could potentially damage/harm the decking. If you are unsure which screw/nail to use, contact your manufacturer for more information.

Recommend screws from other manufacturers: Cap-tor xd screws by Starborn Industries

Acclimate

Acclimating at least 2 days prior to installation is recommended.

Acclimating the boards will get rid of any unwanted shrinkage issues seen during and after installation.

Note: Always remember when allowing the boards to acclimate at the job site it is important to put it on a flat and even surface. If put on an uneven surface there is a possibility that the boards could warp to the shape of the terrain.

Routing

Solid boards can be routed for hidden fasteners to be placed in them, as shown in [Diagram 4](#).

Please Note: Boards should never be routed the entire length.

Fascia boards can also be routed to allow for expansion and contraction.

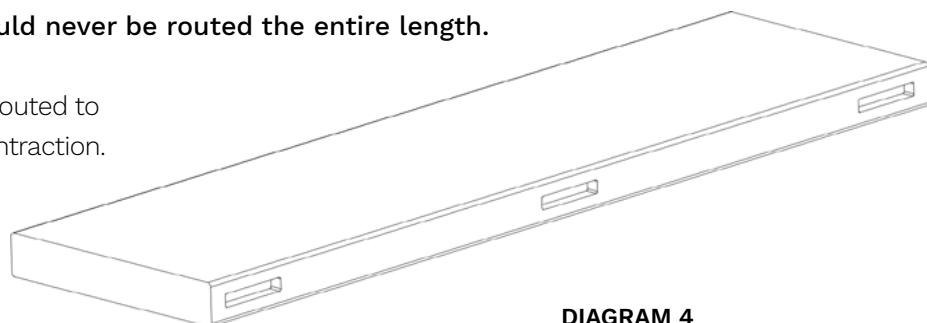
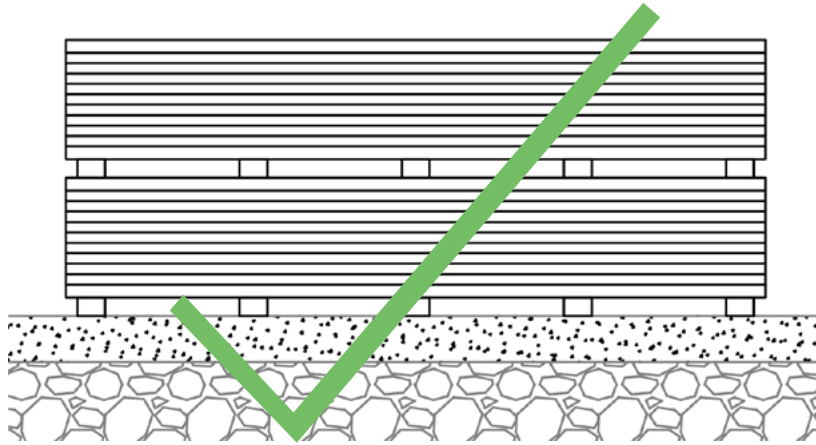

DIAGRAM 4

Storage

NewTechWood's products always need to be stored on flat solid surfaces. Surfaces such as dirt and grass are not sufficient as they can move over time.



NewTechWood products shown above put on a flat surface on joists, this is the correct way for storage.

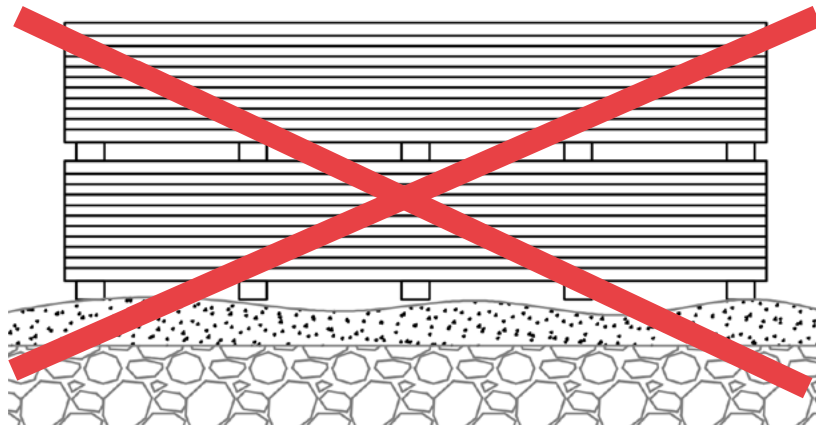

NewTechWood products shown above on an uneven surface which will make the products prone to warping and distortion.

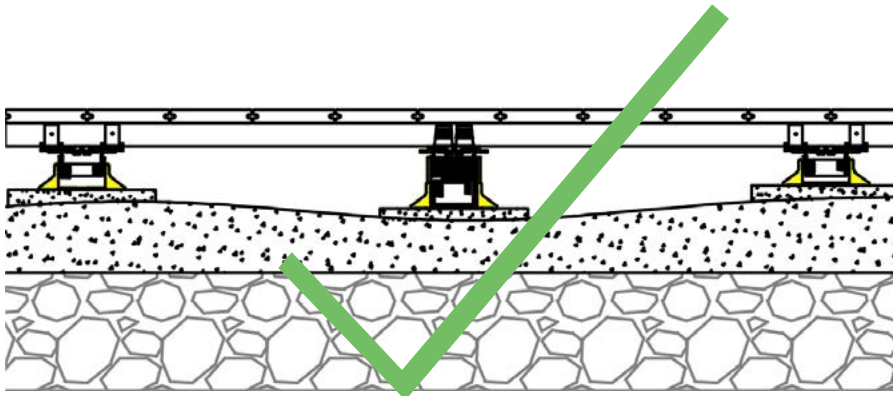

NewTechWood products shown above can be on pedestals or jacks if the surface is uneven. Consult with the pedestal or jack manufacturer before using the product to ensure its compatibility with NewTechWood's products.

Joist Installation for Framing

First, determine the decking span, that is , how far apart your joists will be.
The frame needs to be completely level before installing any boards.

Please Note:

Adequate spacing in the joists is required to keep the deck boards from bending. Please review the chart below to see what spacing is required for your profile.

Maximum Decking Spans on Center-to-Center

Region	Profile	Dimensions	Residential Span	Commercial Span
North America South America South Africa Europe South Korea	US01, Grooved Solid Board	138 x 22.5 mm (5 7/16" x 7/8")	400 mm (15 3/4")	300mm (11 13/16")
	US07, Solid Board	138 x 22.5 mm (5 7/16" x 7/8")	400 mm (15 3/4")	300mm (11 13/16")
	UH02, Grooved Circle Hollow Board	138 x 22.5 mm (5 7/16" x 7/8")	400 mm (15 3/4")	300mm (11 13/16")
	UH06, Grooved Channeled Square Hollow Board	140 x 22.5 mm (5 1/2" x 7/8")	350 mm (13 3/4")	Only to be used for residential

Joist Spanning on Center-to-Center with Angled Decking Installations

Degree of Angle	Dimensions	Spacing
90	138 x 22.5 mm (5 7/16" x 7/8")	Refer to the above tables
60	138 x 22.5 mm (5 7/16" x 7/8")	50 mm (1 15/16") less than the stated above tables
45	138 x 22.5 mm (5 7/16" x 7/8")	100 mm (3 15/16") less than the stated above tables
30	138 x 22.5 mm (5 7/16" x 7/8")	1/2 the distance stated in the above tables

Expansion and Contraction Values

NewTechWood deck boards will experience expansion and contraction with changes in temperature. Expansion and contraction are most significant where extreme temperature changes occur. Fastening the deck planks according to the gapping requirements noted in the following table accommodates for this movement.

Expansion and Contraction table of values for Europe, Russia, Northern Asia

		Length (Meters)									
		1	2.44	2.8	3	3.66	3.9	4	4.88	5.4	
Installation Temperature (°C)	-10	2.4	5.9	6.7	7.2	8.8	9.4	9.6	11.7	13.0	Gap (mm)
	-5	2.2	5.4	6.2	6.6	8.1	8.6	8.8	10.7	11.9	
	0	2.0	4.9	5.6	6.0	7.3	7.8	8.0	9.8	10.8	
	5	1.8	4.4	5.0	5.4	6.6	7.0	7.2	8.8	9.7	
	10	1.6	3.9	4.5	4.8	5.9	6.2	6.4	7.8	8.6	
	15	1.4	3.4	3.9	4.2	5.1	5.5	5.6	6.8	7.6	
	20	1.2	2.9	3.4	3.6	4.4	4.7	4.8	5.9	6.5	
	25	1.0	2.4	2.8	3.0	3.7	3.9	4.0	4.9	5.4	
	30	0.8	2.0	2.2	2.4	2.9	3.1	3.2	3.9	4.3	
	35	0.6	1.5	1.7	1.8	2.2	2.3	2.4	2.9	3.2	
40	0.4	1.0	1.1	1.2	1.5	1.6	1.6	2.0	2.2		

Please Note:

If you are still unsure of what gapping to use, contact the manufacturer and they will give you the correct gapping requirements based on your environment and area.

Locking the Decking Boards

NewTechWood deck boards must allow for expansion and contraction with changes in temperature. The decking boards must be locked at one fixed point but only one point to allow the remaining board to expand and contract freely.

Please Note:

It is essential that **USE ONLY ONE** locking clip (e.g., TC-1, TC-10, or MG-2A) for the same board,

We recommend locking the decking board in the middle to allow for evenly expansion and contraction to take place on both ends, as shown in *Diagram 5-1*.

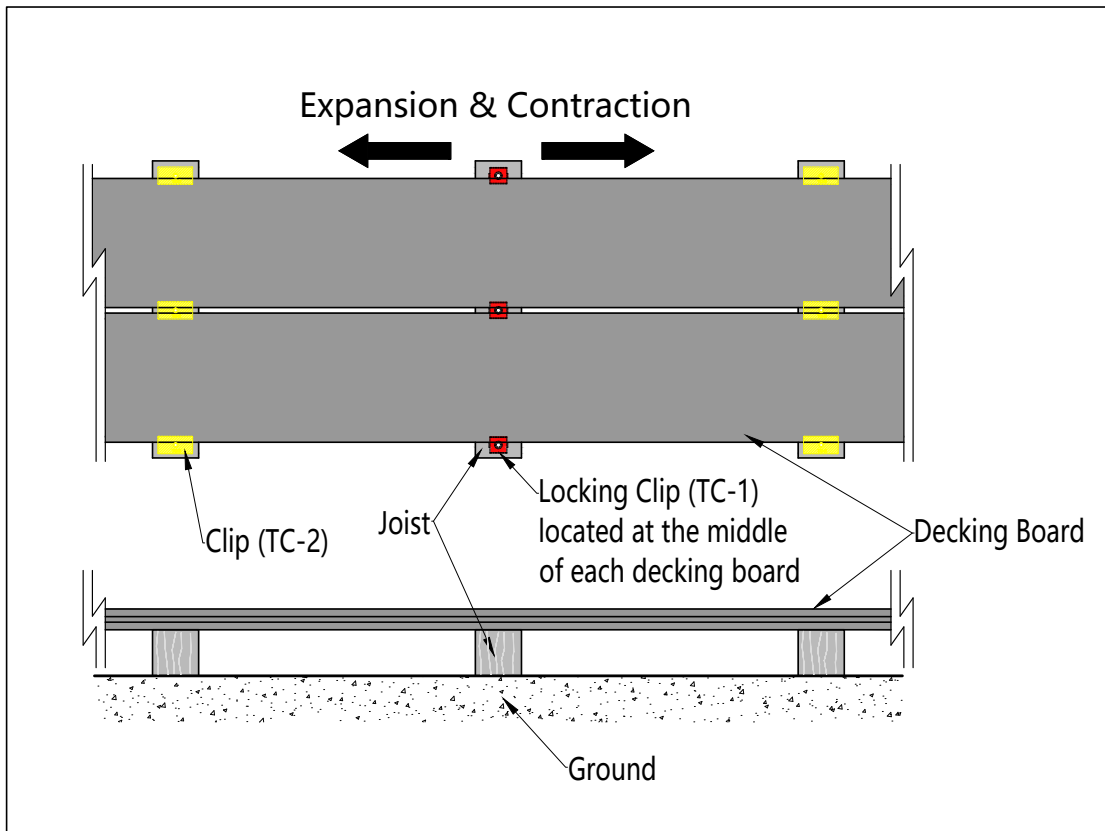
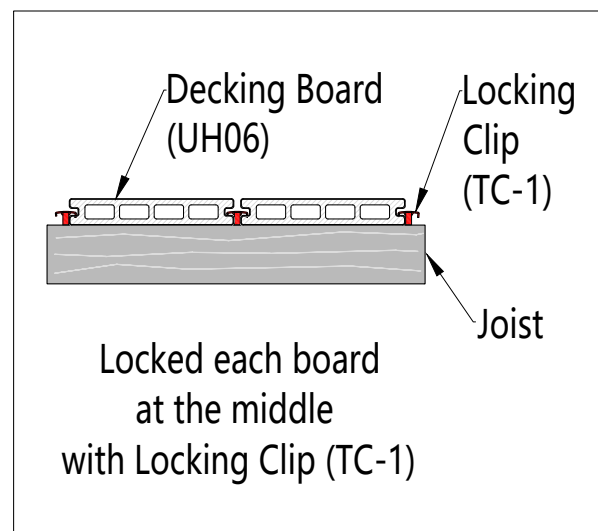

DIAGRAM 5-1

We are using the decking board **UH06** and the locking clip (**TC-1**), as shown in *Detail 5-1-1*, for this installation explanation. The gap at the end of the decking board on both ends and between the butt joint boards is vital to avoid warping and buckling. According to the *Expansion and Contraction Values*, please select the appropriate gap value on *page 8* of this installation guide.



Detail 5-1-1

1. One full length board across the deck

Diagram 5-2 shows installing boards one full length across the deck. Please select the gap value shown in the **Expansion and Contraction Values** for the gap at the end of the decking boards on both ends, as shown in **Detail 5-2-1**.

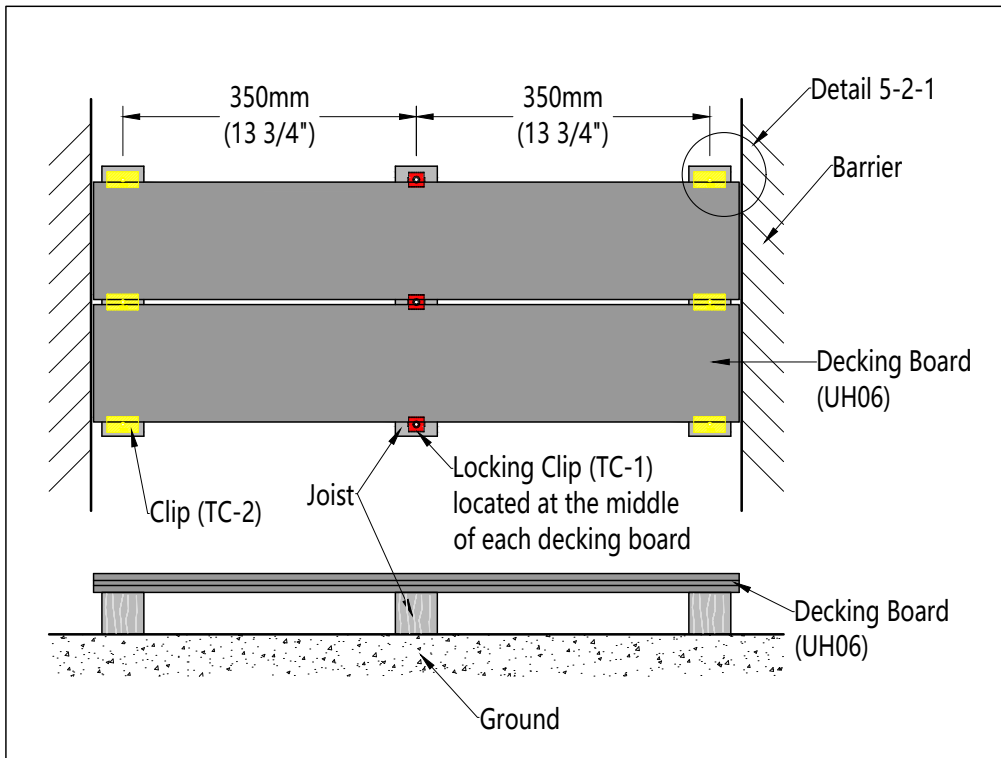
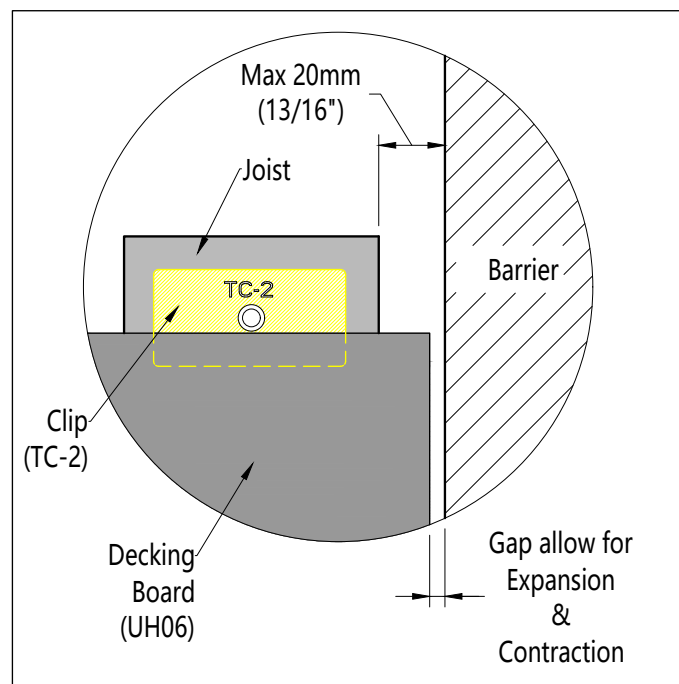

DIAGRAM 5-2



Detail 5-2-1

2. Two boards across the deck

Diagram 5-3 shows installing boards with two deck boards across the deck. According to the **Expansion and Contraction Values**, please select the appropriate value for the gap between the butt joint boards, as shown in **Detail 5-3-1**. And for the gap at the end of the decking boards on both ends, as shown in **Detail 5-3-2**.

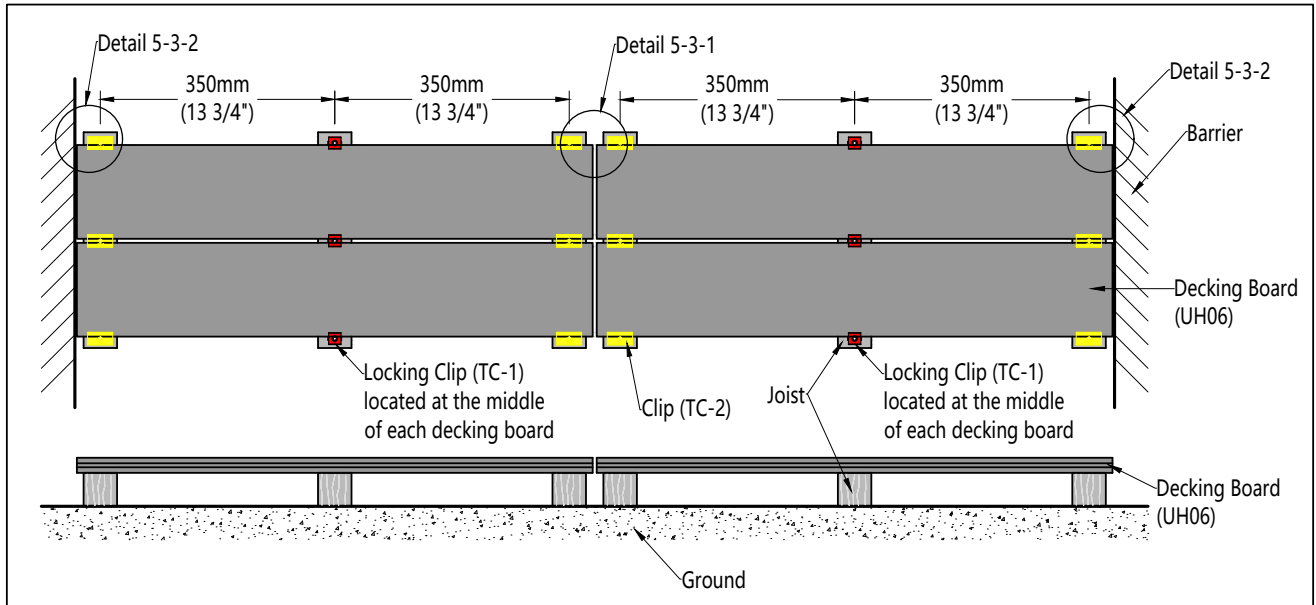
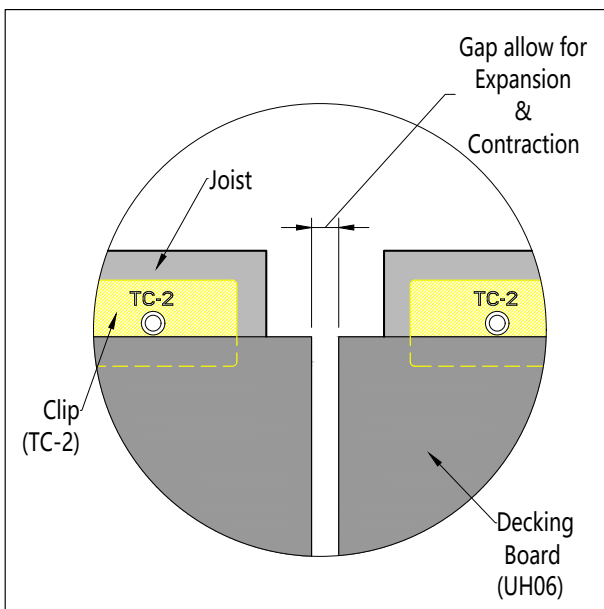
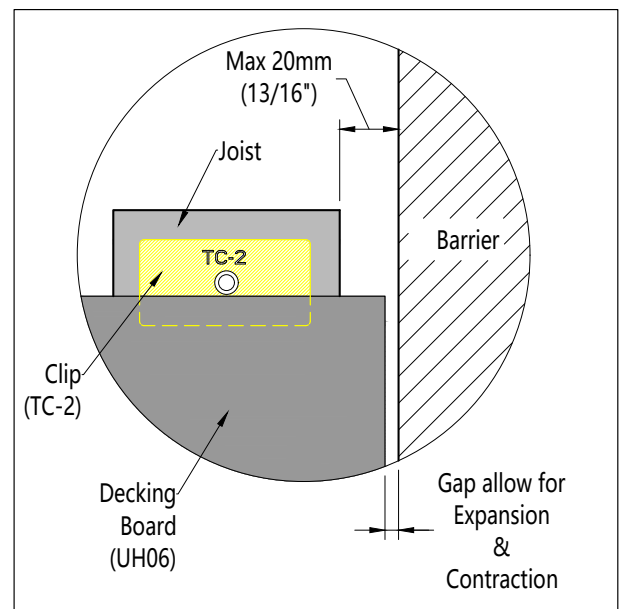

DIAGRAM 5-3



Detail 5-3-1



Detail 5-3-2

3. More than Two boards across the deck

Diagram 5-4 shows installing boards with more than two deck boards across the deck. According to the **Expansion and Contraction Values**, please select the appropriate value for the gap between the butt joint boards, as shown in **Detail 5-4-1**. And for the gap at the end of the decking boards on both ends, as shown in **Detail 5-4-2**.

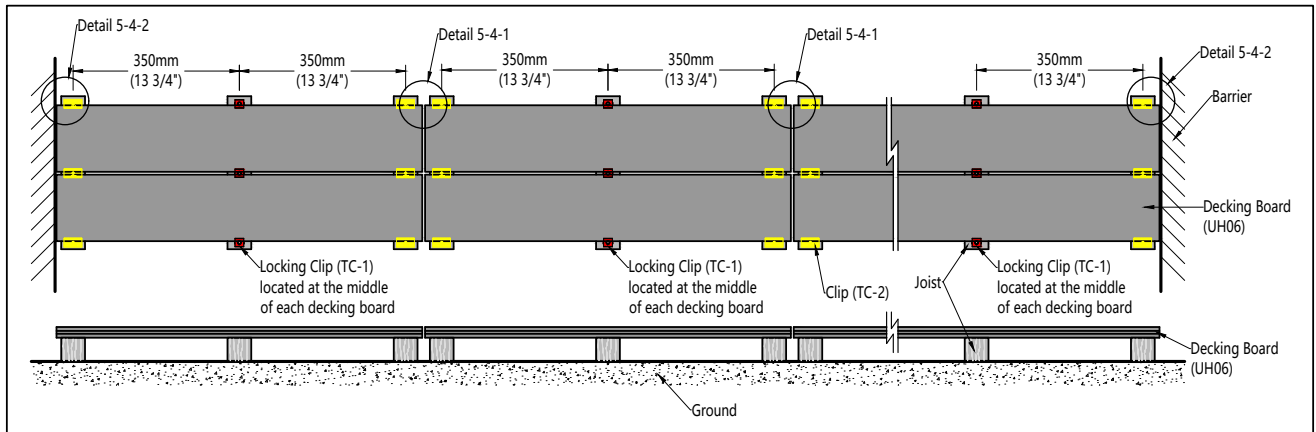
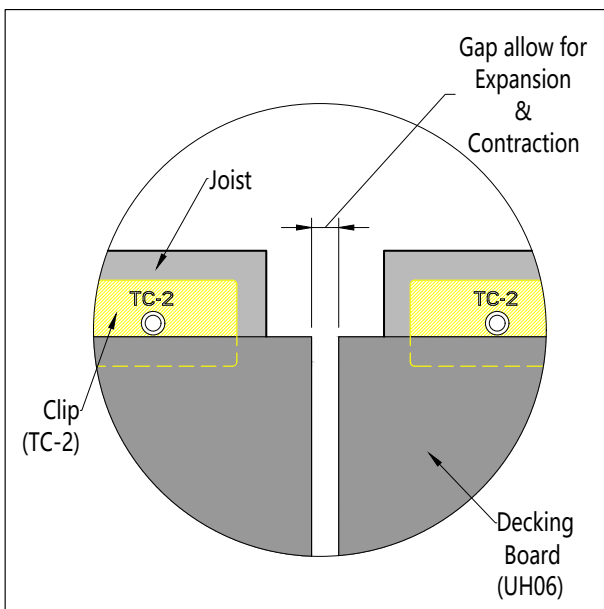
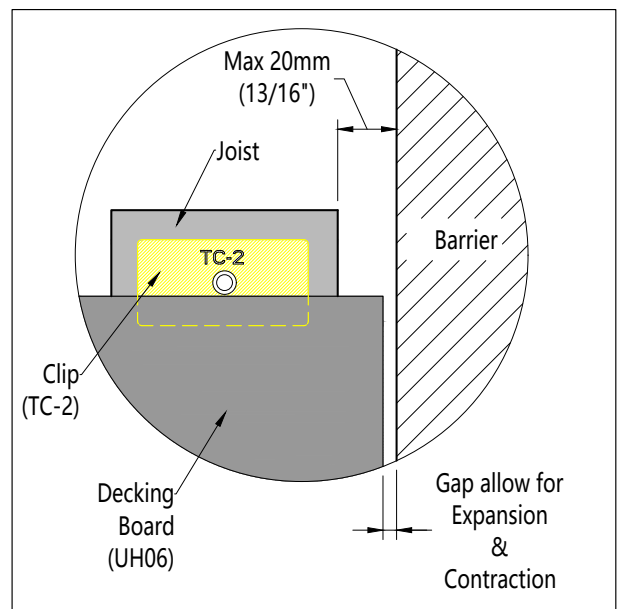

DIAGRAM 5-4



Detail 5-4-1



Detail 5-4-2

The below shows the recommended installation methods using ***picture framing the decking with breaker boards***, as shown in ***Diagram 6A***, and breaker boards only, as shown in ***Diagram 6B***. Locking clips should be placed as close as possible to the middle joist of each board.

If you plan to install without breaker boards or picture framing in a brick style fashion it is recommended that you contact your local distributor or the manufacturer for further instructions. Installing with a brick style could potentially give large gaps between butt ends due to the products expansion and contraction rates. It could also make the ends of the deck flare or swell if water is not properly drained on the joist specifically at a butt end where sister joists with a gap should be used.

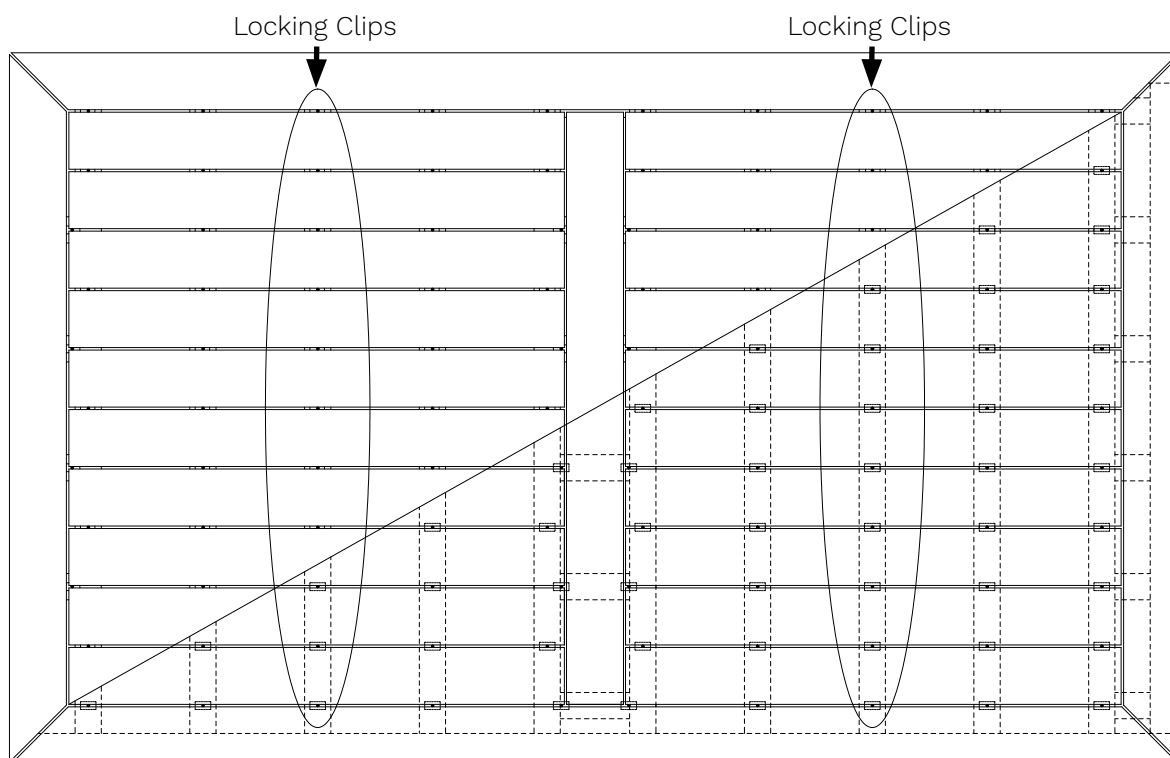

DIAGRAM 6A

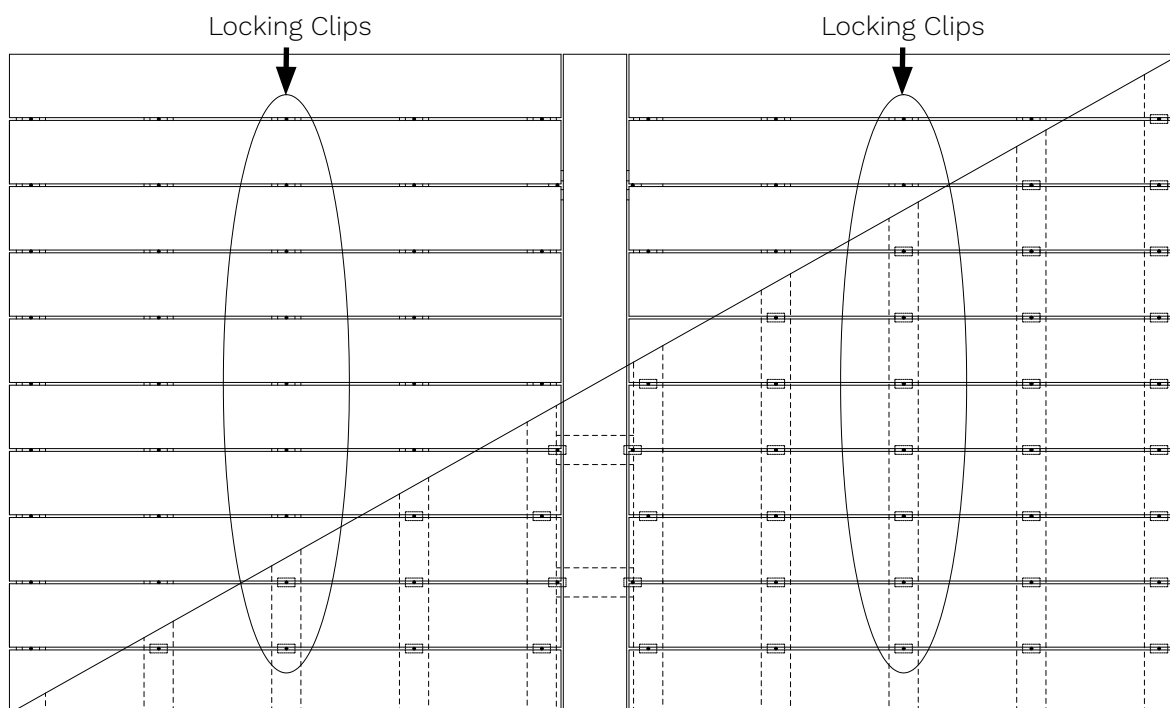

DIAGRAM 6B

Breaker Board Installation

Diagram 7 and 8 below show how framework and installation of the breaker board respectively.

Diagram 7 framework uses a ladder joist installation where the user is building a frame perpendicular for the board that will be running down it.

Note: The T-Clip (TC-2) can be used as a breaker board clip by cutting it, as shown in Diagram 9.

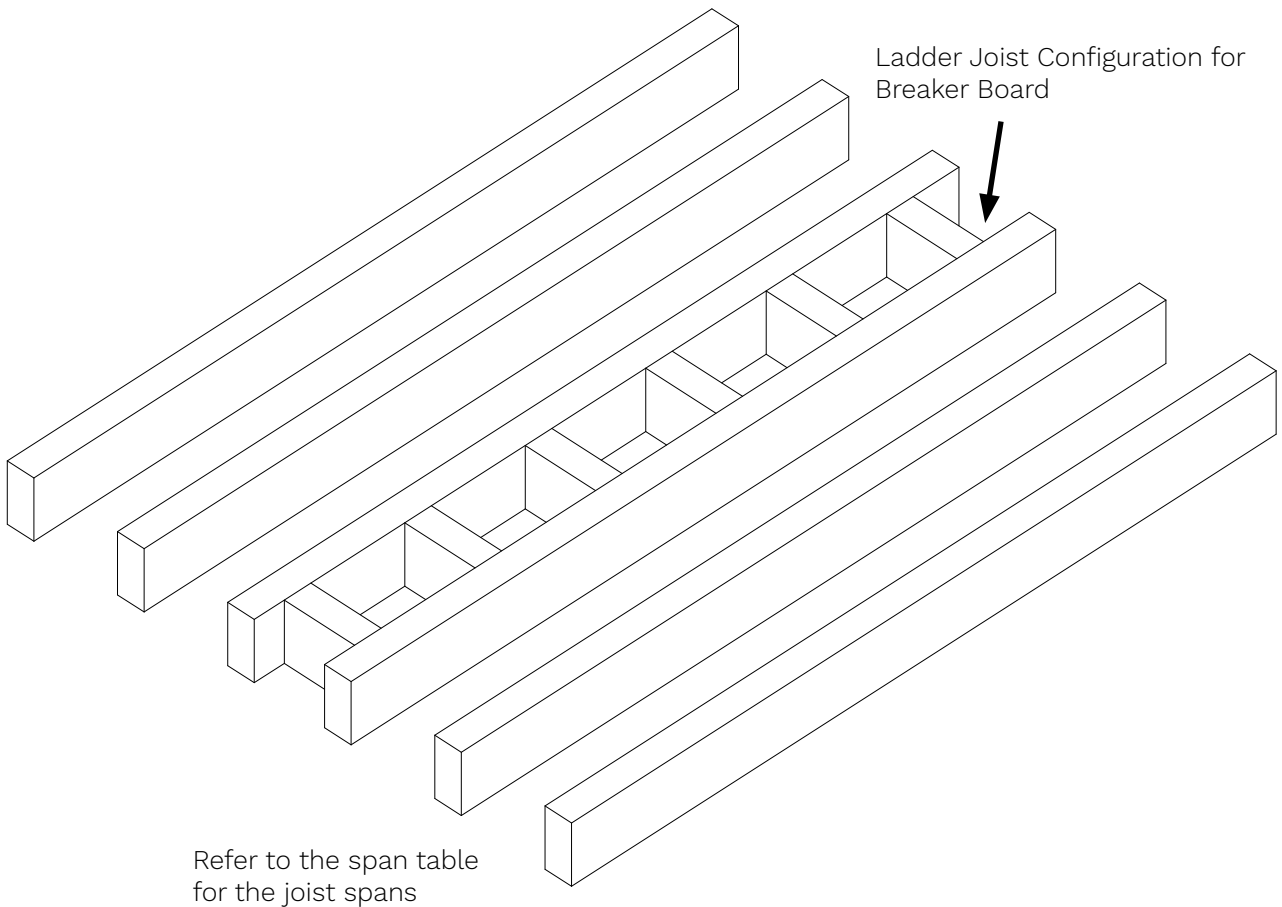
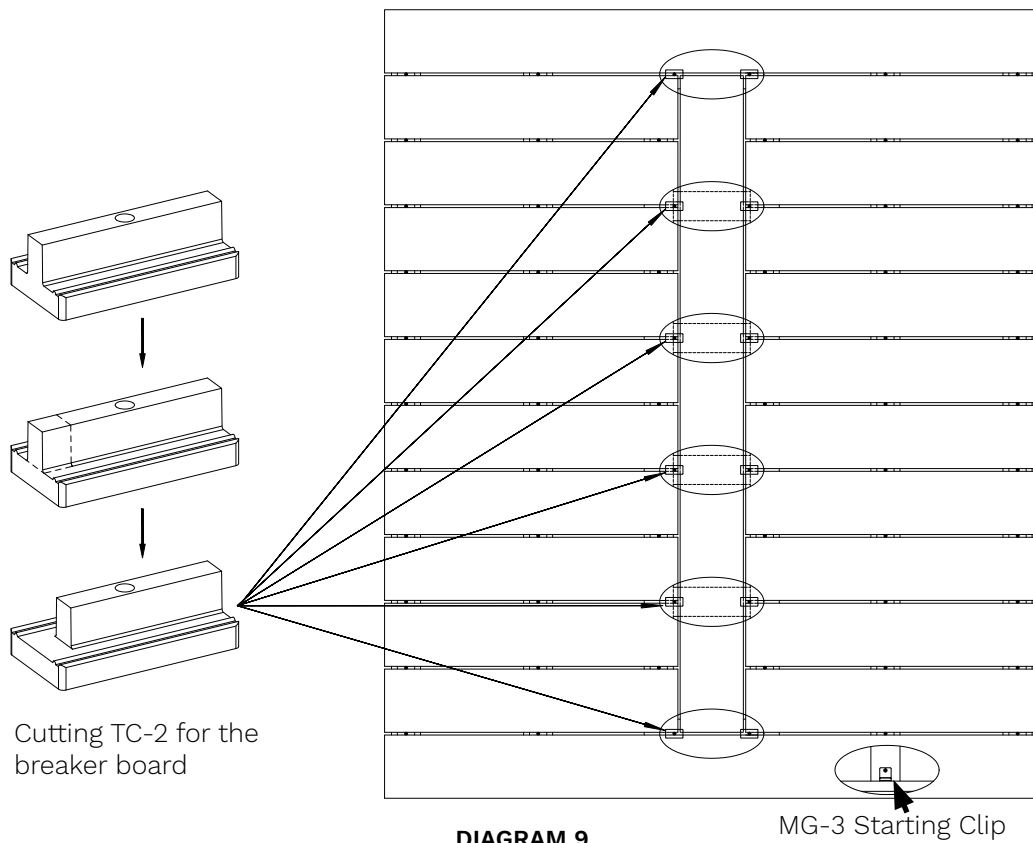
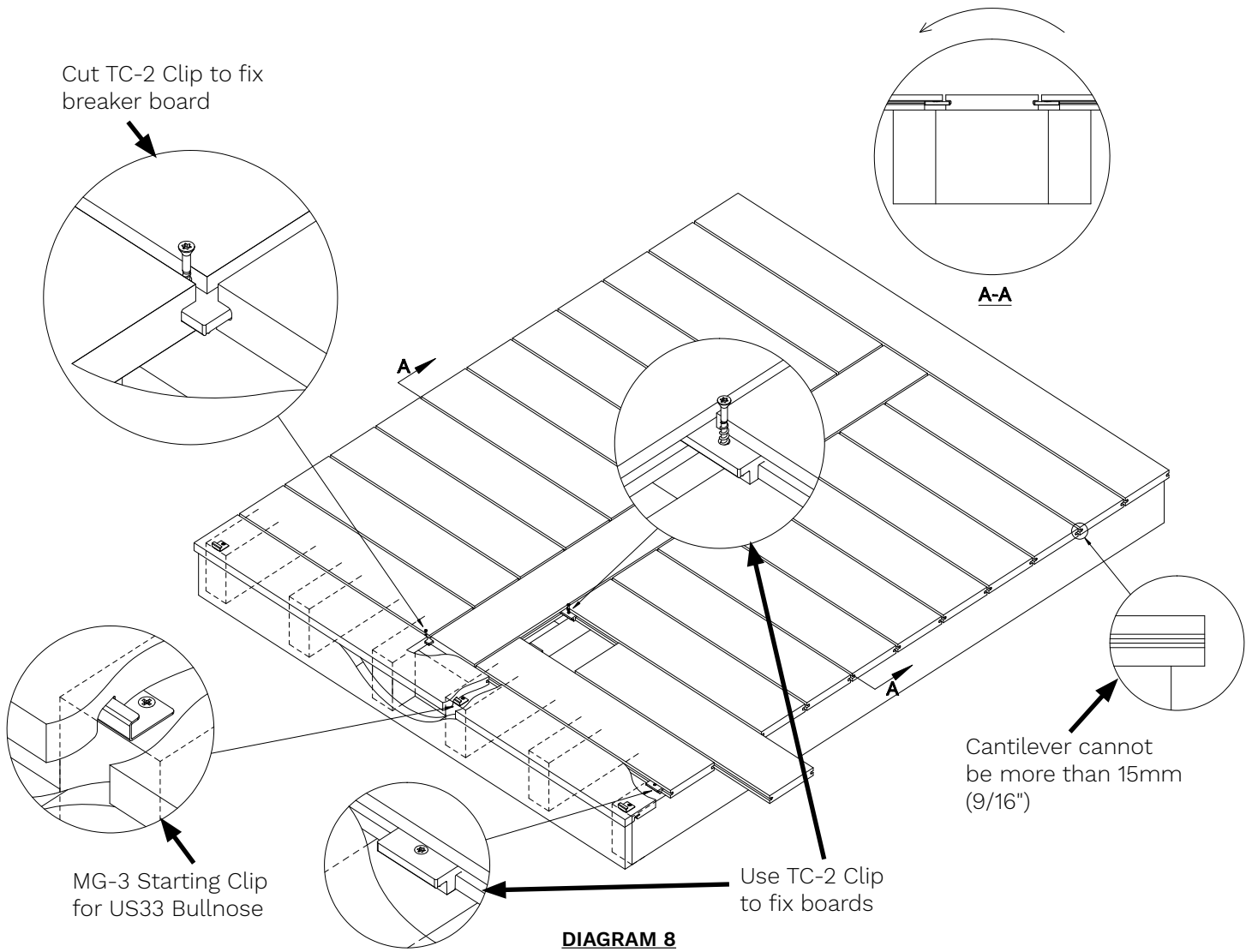

DIAGRAM 7



Stair Treads Installation

Review [Diagram 10](#) and the table below with the maximum spacing from center to center for stair tread installation.

Stair treads built with NewTechWood must meet requirements by the major national building codes. Consult your local municipality for specific requirements.

Please Note:

1. Stair treads should only be installed using solid profiles. Using any type of hollow board for stair treads will not be warranted.
2. A minimum of four (4) stringers are required.
3. Overhang on a stair tread should not exceed more than 15mm (5/8").

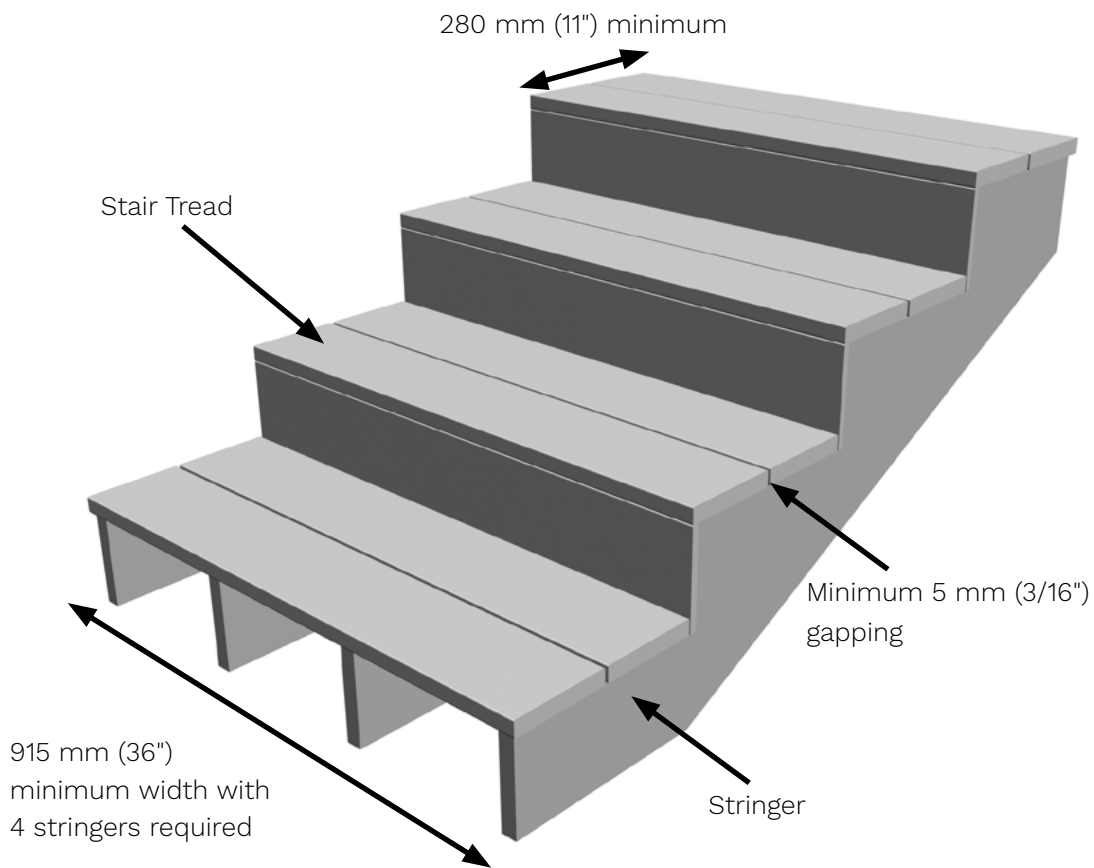

DIAGRAM 10

Maximum Spacing Center-to-Center on Stair Stringers and Bullnose

Profile	Dimensions	Spacing
US07 Solid Board	138 x 22.5 mm (5 7/16" x 7/8")	305 mm (12")
US01 Solid with Grooves	138 x 22.5 mm (5 7/16" x 7/8")	305 mm (12")
US33 Bullnose	138 x 22.5 mm (5 7/16" x 7/8")	305 mm (12")

Bullnose Installation

Use the table on the previous page to determine the center to center spacing for the bullnose profile.

A minimum of four (4) stringers are required when installing the bullnose profile.

Overhang on the bullnose board should not exceed more than 15 mm (5/8").

Starting Accessory Installation:

First, determine how many boards your stair is going to take to finish (with clips) and then you can start to measure where the TC-5/MG-3 starting clip will go. Use a white chalk line (NEVER USE COLORED CHALK) to ensure that all TC-5/MG-3 starting clips are lined up on each joist.

Note: The bullnose profile can only cantilever 15 mm (5/8"). If the bullnose profile cantilevers more than this, the warranty will be voided.

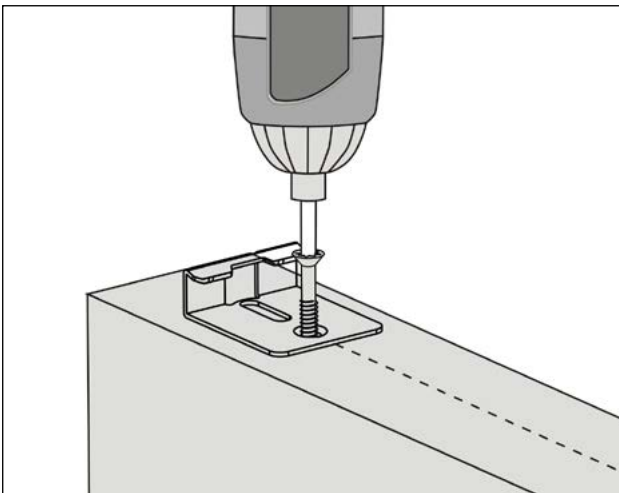

DIAGRAM 11

Bullnose Installation:

- 1 Now take the bullnose profile and place it right over all the TC-5/MG-3 starting clips and push down, as show in [Diagram 12](#).

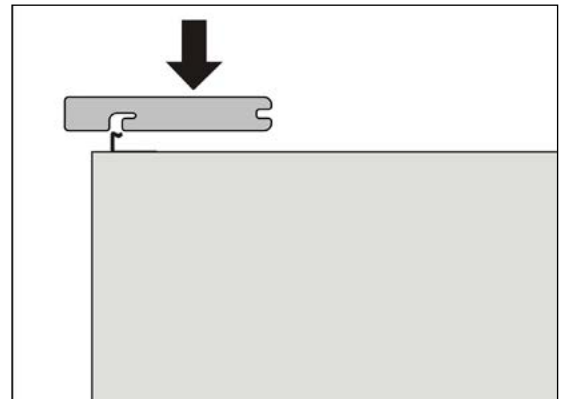

DIAGRAM 12

- 2 Now that the TC-5/MG-3 starting clips are inside the underside of the bullnose, the final step is to push forward to ensure that it secured into place, as shown in [Diagram 13](#).

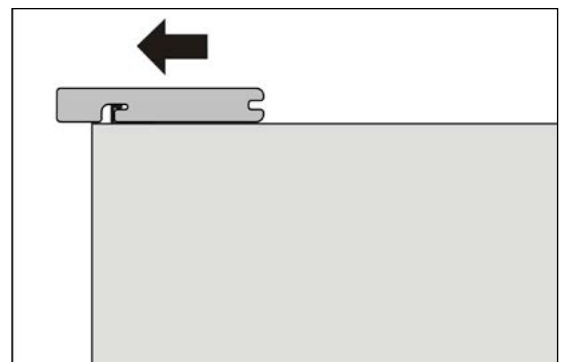

DIAGRAM 13

- 3 Now take the next board and have it situated behind the bullnose profile, as shown in **Diagram 14**.

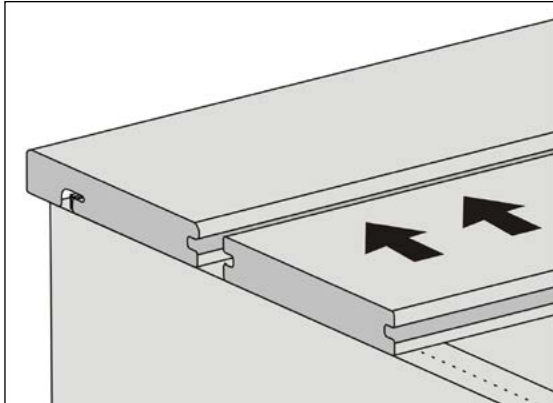

DIAGRAM 14

- 4 Slide in the clips into the two grooves and glide them along until they are on their respective joists and then screwing down onto the joists, as shown in **Diagram 15 and 16**.

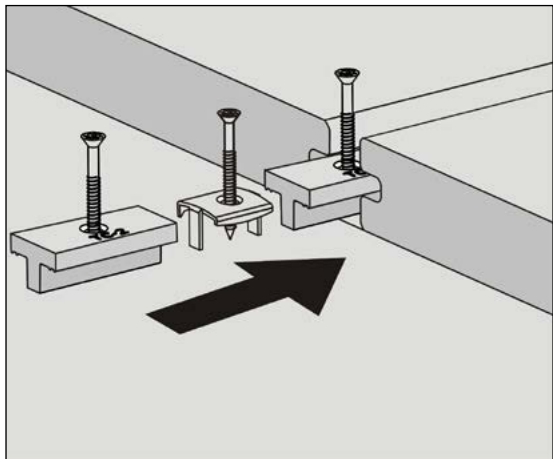

DIAGRAM 15

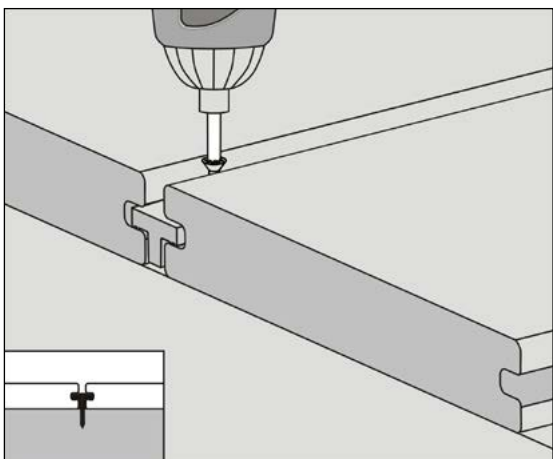

DIAGRAM 16

- 5 Finally, finish your last board by face fixing into the board at every joist, as shown in **Diagram 17**.

Please Note:

Remember to pre-drill before face fixing into the board. Also face fixing must happen at a 90 degree angle and must be at least 38.1 by 38.1 mm (1 1/2" by 1 1/2") from the ends and the width of the board.

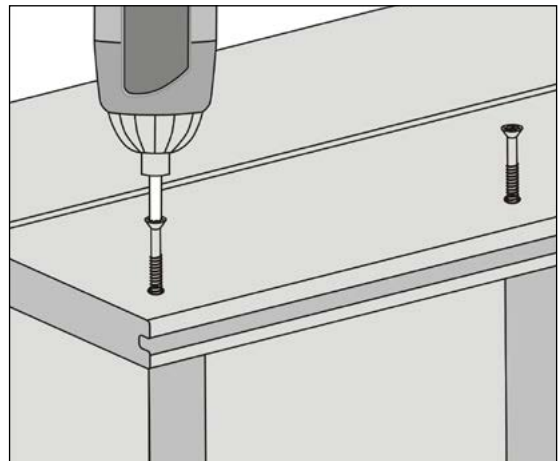

DIAGRAM 17

Diagram 18 below shows a completed staircase from the side to get a better idea of how the final installation will look.

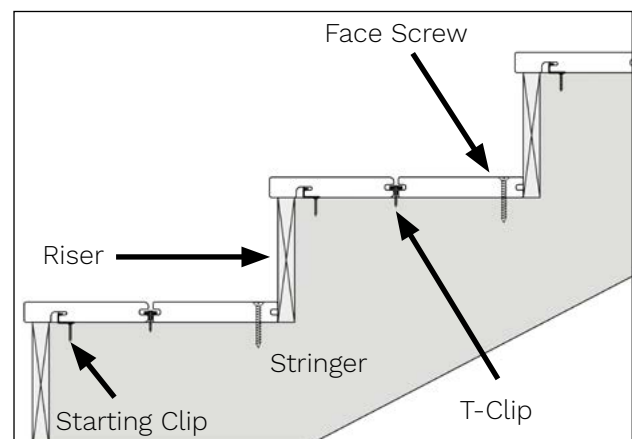

DIAGRAM 18

Decking Installation

First, determine the decking span, that is, how far apart your joists will be. The frame needs to be completely level before installing any boards.

Please Note:

Adequate spacing in the joists is required to keep the deck boards from bending. Please review the chart on [page 7](#) of this installation guide to see what spacing is required for your profile.

When installing the deck, the first and last board of your project will need to use a starting accessory. Every other board will use the hidden fastener for its installation.

Overhang on boards outermost edge should not exceed more than 15 mm (5/8").

Starting Accessory Installation:

- 1 After calculating the decking span and making the frame of your deck, the first board is ready to be installed.
- 2 Pre-drill into the joist, then fix the starting accessory into the joist, as shown in [Diagram 19](#).

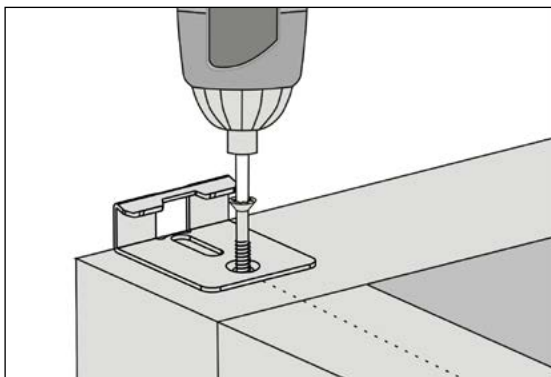

DIAGRAM 19

- 3 Then, take your first board and push it into the starting accessory, as shown in [Diagram 20](#).

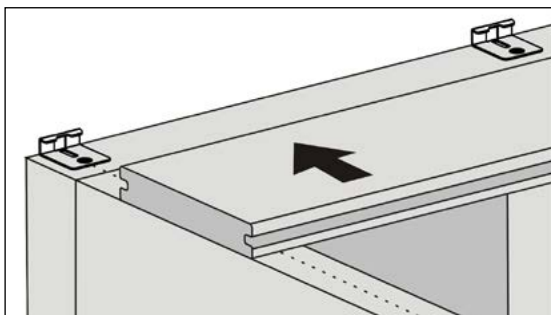
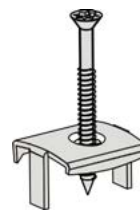

DIAGRAM 20

Option 1:

T-Clip and TC-1 Locking Clip Installation

- 1 First, slide the TC-1 and TC-2 clips into the grooves of the boards with screws facing up, as shown in [Diagram 21](#).



Locking Clip (TC-1)

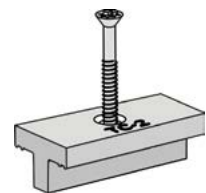

T-Clip (TC-2)

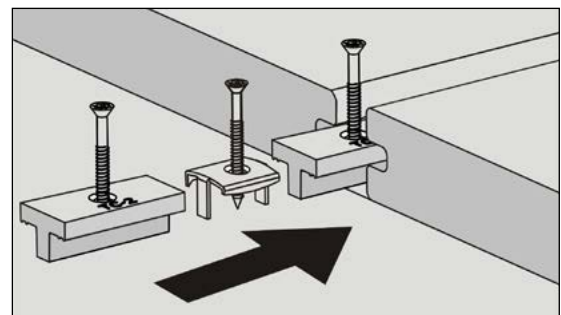

DIAGRAM 21

- 2 After getting all the TC-1 and TC-2 clips into position above each respective joist, begin to fasten them from above, as shown in [Diagram 22 and 23](#).

Please Note:

The fastest way of installation is by pushing all the boards together and then coming back and sliding the clips into the grooves from the side and then fixing from above.

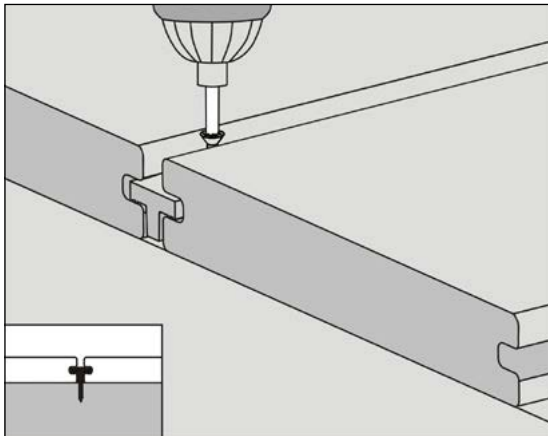

DIAGRAM 22

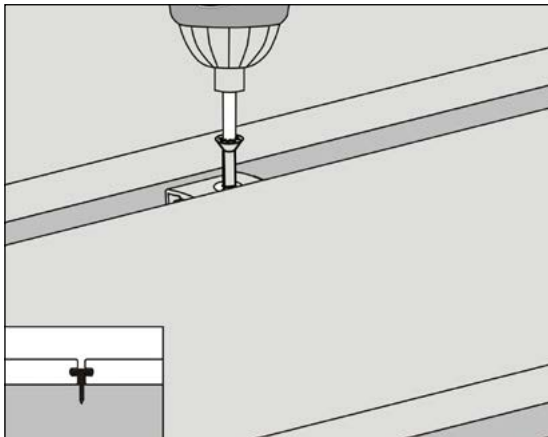

DIAGRAM 23

- 3 Repeat steps 1-2 until the deck is complete.
- 4 The final installed clips should look like [Diagram 24](#).

Please Note:

The locking clip is in the middle [Diagram 24](#) to show the expansion and contraction is happening in both directions. For more information on how to install the locking clips and their placement, check [page 9-13](#) of this installation guide.

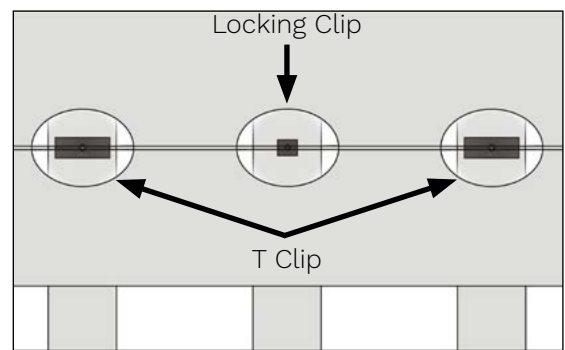

DIAGRAM 24

Option 2:

Mini Gap Clip Installation

Please Note:

The following shows how to install the mini gap clip system. A starting accessory (MG-3/TC-5) still needs to be used to install the first board.

- 1 First, slide the MG-1A and MG-2A clips into the grooves of the boards, as shown in *Diagram 28*.

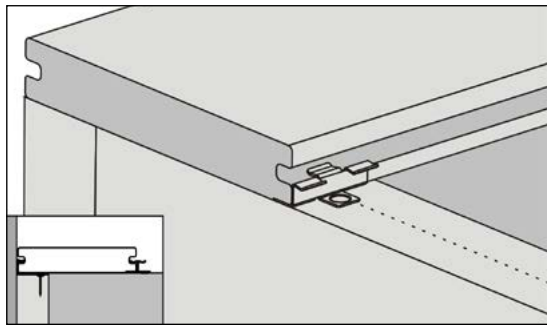
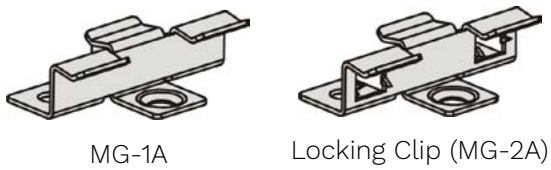

DIAGRAM 28

- 2 Place a screw in the outside hole of the MG-1A and MG-2A as shown in *Diagram 29*.

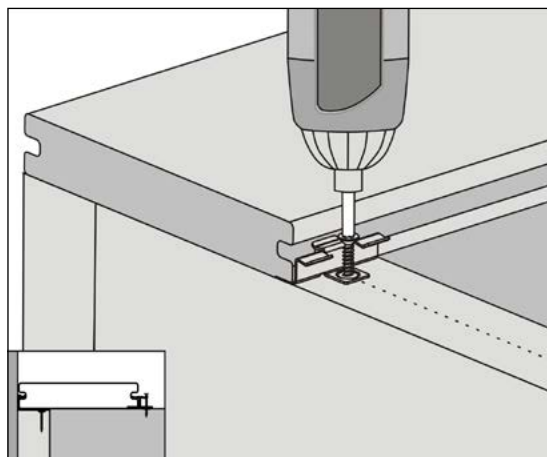

DIAGRAM 29

- 3 Next, fix the screw down into the joist as shown in *Diagram 30*.

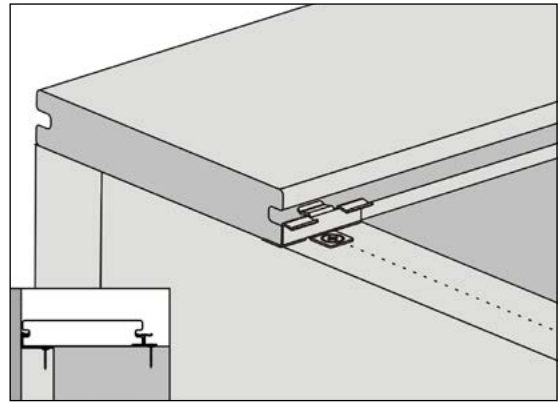

DIAGRAM 30

- 4 After fixing all clips, push the next board into the clips as shown in *Diagram 31 and 32*.

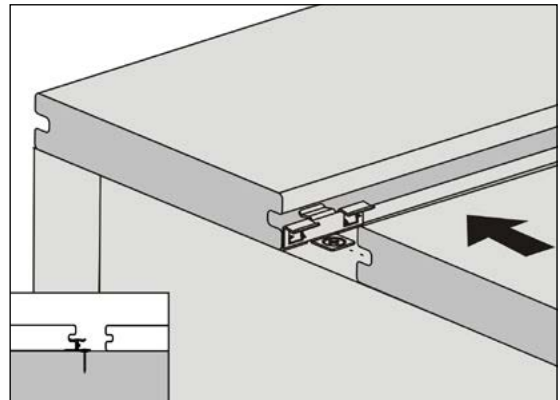

DIAGRAM 31

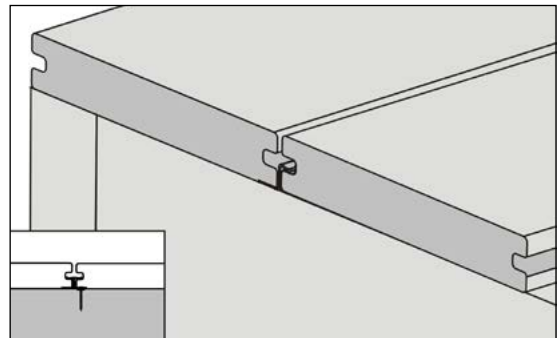

DIAGRAM 32

5 Repeat steps 1-4 until complete.

6 The final look should be like the below **Diagram 33**.

Please Note:

The locking clip is in the middle of **Diagram 33** to show the expansion and contraction is happening in both directions. For more information on how to install the locking clips and their placement, check [page 9-13](#) of this installation guide.

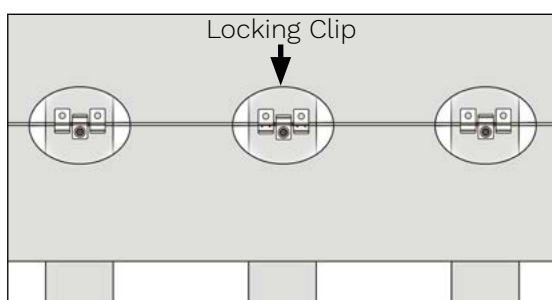

DIAGRAM 33

Fascia Board Installation

Installing against the width and length of decking

1 Fascia boards with a thickness of less than or equal to 10 mm need to be installed on 300mm (11 13/16") on centers to prevent warping or buckling. Fascia boards with a thickness greater than 10mm (3/8") can be installed on 400mm (15 3/8") on centers. All fascias need to use two screws 38.1mm (1 1/2") away from the ends as shown in **Diagram 34** regardless of the thickness.

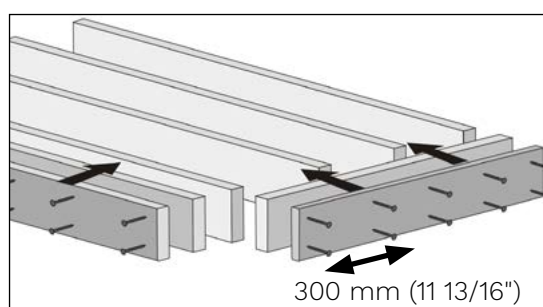

DIAGRAM 34

2 First, pre-drill the holes for the fascia board. The fascia board should be drilled with bigger holes or routed to allow for expansion and contraction and fixed either at either end or in the middle as shown in **Diagram 36**. When fixing the bigger holes, it is recommended to use washers.

3 The fascia board will be installed into the block wood and through the joist.

Please Note:

NEVER install the fascia by drilling into the decking. **ALWAYS** install the fascia into the joist and **ALWAYS** pre-drill the fascia board.

End Cap Installation

- 1 Place the end cap in front of the hollow boards holes and push in as shown in [Diagram 35](#).

Please Note:

A mallet could be used as well to push in the end caps.

- 2 The final finish should look like [Diagram 36](#) below.

Please Note:

A dab of silicon can be used on the end cap or inside the holes of the board in order to secure the end caps better.

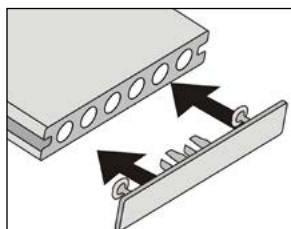

DIAGRAM 35

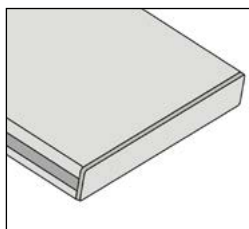

DIAGRAM 36

Removing a board

- 1 Start by unfastening all the clips from the joist on both sides of the board, as shown below in [Diagram 37](#).

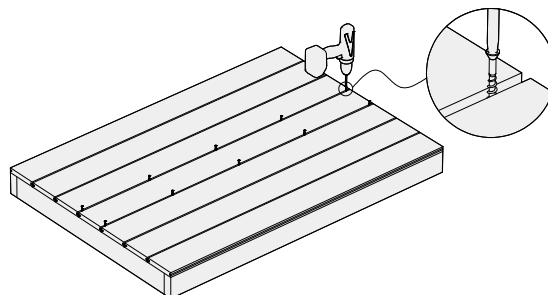

DIAGRAM 37

- 2 Next slide all clips out of the board as shown below in [Diagram 38](#).

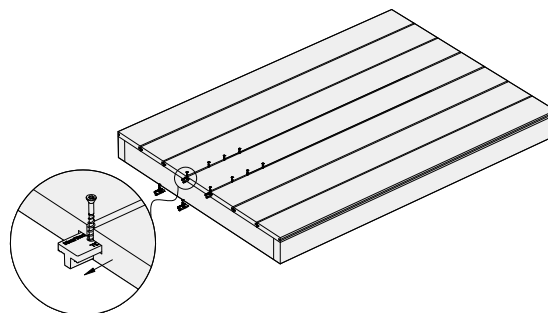

DIAGRAM 38

- 3 Next slide out the board, as shown below in [Diagram 39](#).

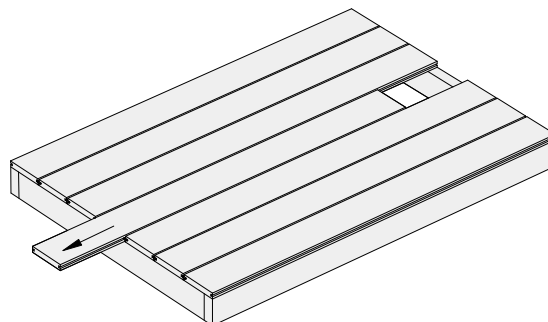

DIAGRAM 39

- 4 After the board is removed the new board can be inserted as shown below in **Diagram 40 and 41.**

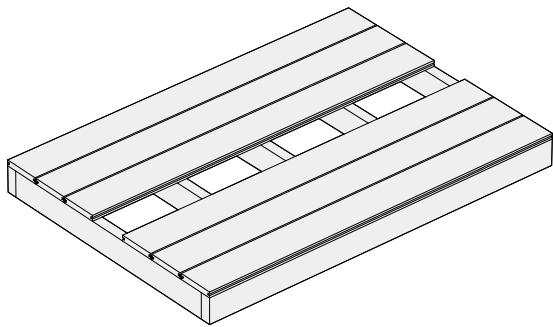

DIAGRAM 40

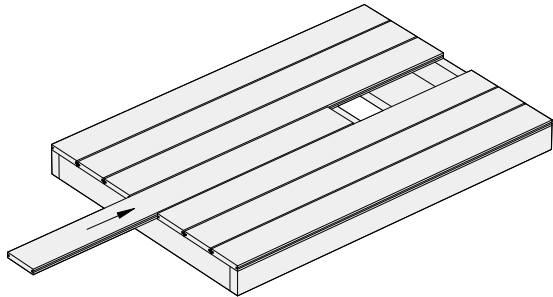

DIAGRAM 41

- 5 After the new board is in position insert the clips through the groove and into the correct position, as shown in **Diagram 42.**

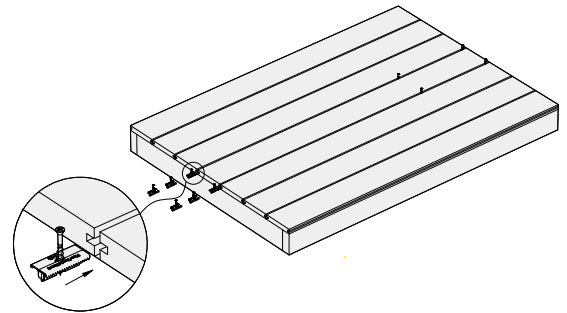

DIAGRAM 42

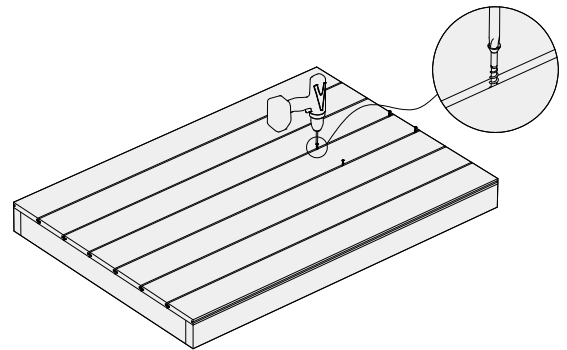

DIAGRAM 43



Decking Installation Guide

O21GE18UK

©2021 Newtechwood Corporation

NewTechWood® is a registered trademark of Newtechwood Corporation.

To obtain a copy of the most current version of this installation guide,

visit us online at www.newtechwood.uk



TECHNICAL INFORMATION



POSTCRETE

Ready-to-use Blue Circle Postcrete Product Data Sheet

A ready-to-use blend of selected sand, cement and additives formulated for fixing wooden, concrete and metal posts.

USES

To fix all types of wood, metal and concrete posts.

DESCRIPTION

Blue Circle Postcrete is ready to use. No mixing is required.

PACKAGING

Blue Circle Postcrete is packed in weatherproof 20 kg plastic packaging.

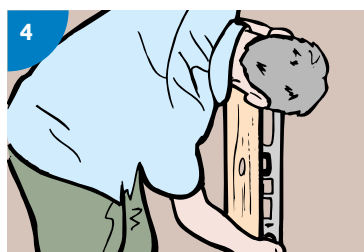
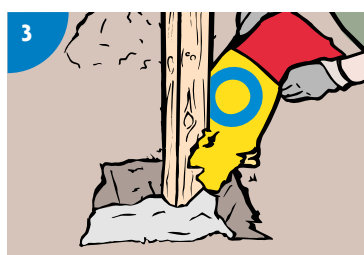
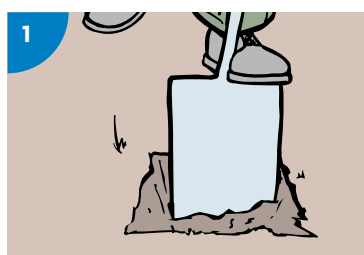

SITWORK

For the best results follow these instructions:

1. Dig a hole relevant to post size - three times wider than the post and as deep as $\frac{1}{3}$ of fence heights above the ground.
2. Fill the hole with water to a third of the depth.
3. Pour in Blue Circle Postcrete evenly around post until no standing water is visible (powder completely covers water surface). Sprinkle water on top of powder.
4. Position and level post as required. Setting will take place in 5 to 10 minutes.
5. When set, cover top of hole with soil or grass.
6. You can fix fence panel right after the initial 10 minutes of post setting time.

Do not mix Blue Circle Postcrete with water by hand or machine. Please consult with the table on the reverse for guidance on the quantity of Blue Circle Postcrete to use or alternatively go to www.tarmac-bluecircle.co.uk/product/postcrete-trade/

STORAGE

Blue Circle Postcrete is a cement-based material and should be handled and stored with care. This product may be stored, unopened in either indoor or outdoor conditions. Information on the maximum storage period can be found on the bag.

CLEANING

All equipment should be cleaned with water. Do not flush down drains.

AVAILABILITY

Blue Circle Postcrete is available throughout the United Kingdom. Blue Circle Postcrete is supplied in 20 kg plastic bags.

CONDITIONS OF USE

- Blue Circle Postcrete may be used for the purposes of fixing domestic posts
- Blue Circle Postcrete may be used for fixing decking posts, rotary washing lines and small/medium sized gateposts (less than 1.0m width gate)
- Blue Circle Postcrete may not be used for general concreting, screeds, mortar, grout or render
- If a specified compressive strength is required, Blue Circle Postcrete should not be used
- Normal site practice to the relevant British and European Standards should always apply. Tarmac Cement cannot be held responsible where workmanship has not been carried out in accordance with good practice
- Manual handling should comply with *The Manual Handling Operations Regulations 1992*.

TECHNICAL SUPPORT

Further information and advice on this product and the full range of Tarmac Cement products can be obtained through the contacts listed below.

HEALTH AND SAFETY

Contact between cement powder and body fluids (eg, sweat and eye fluids) may cause irritation, dermatitis or burns. For further information, including control of soluble hexavalent chromium, refer to the appropriate Tarmac Cement Health and Safety Information Sheets.

Post size	Hole size (width x depth)	Number of bags required
Round 5cm (2")	15cm (6") x 30cm (12")	1/4 bag
	15cm (6") x 45cm (18")	1/3 bag
	15cm (6") x 60cm (24")	1/2 bag
	20cm (8") x 30cm (12")	1/2 bag
	20cm (8") x 45cm (18")	3/4 bag
Square 7.5cm (3")	20cm (8") x 60cm (24")	1 bag
	15cm (6") x 45cm (18")	1/3 bag
	15cm (6") x 60cm (24")	1/2 bag
	15cm (6") x 75cm (30")	3/4 bag
	20cm (8") x 45cm (18")	3/4 bag
	20cm (8") x 60cm (24")	3/4 bag
	20cm (8") x 75cm (30")	1 bag
	25cm (10") x 45cm (18")	1 1/3 bags
	25cm (10") x 60cm (24")	1 1/2 bags
	25cm (10") x 75cm (30")	1 2/3 bags
Square 10cm (4")	30cm (12") x 45cm (18")	2 bags
	30cm (12") x 60cm (24")	2 bags
	30cm (12") x 75cm (30")	2 3/4 bags
	20cm (8") x 45cm (18")	2/3 bag
	20cm (8") x 60cm (24")	3/4 bag
	20cm (8") x 75cm (30")	1 bag
	25cm (10") x 45cm (18")	1 1/4 bags
	25cm (10") x 60cm (24")	1 1/3 bags
	25cm (10") x 75cm (30")	1 2/3 bags
	30cm (12") x 45cm (18")	1 3/4 bags
30cm (12") x 60cm (24")	2 bags	
	30cm (12") x 75cm (30")	2 1/2 bags

For further information

Technical helpdesk

Tel: 0845 812 6232

E-mail info-cement@tarmac.com

Customer services & sales

Tel: 0845 812 6300

E-mail customerservice@tarmac.com

Tarmac' and the 'circle logo' are registered trademarks. ©2015 Tarmac Trading Limited

The information in this data sheet is accurate at the time of printing, but Tarmac reserves the right to amend details as part of its product development programme. The information given in this technical data sheet is based on our current knowledge and is intended to provide general notes on our products and their uses. Tarmac endeavour to ensure that the information given is accurate, but accept no liability for its use or its suitability for particular application because of the product being used by the third party without our supervision. Any existing intellectual property right must be observed.